

Design and Installation Specification

February 2020 Edition



OmegaFlex Ltd
Quality
Management
System



FM 517165

TracPipe[®] is
manufactured
and Kitemarked to
BS EN 15266



KM 549666

Warning

When installing, servicing, maintaining or repairing gas appliances and other gas fittings in Great Britain, the Isle of Man, Northern Ireland and Guernsey there are a number of statutory requirements with which to comply. When working on gas, compliance should be achieved by carrying out work in accordance with the relevant standards and following manufacturer's instructions.

Gas work should only be undertaken:

- a) by a person, who has successfully completed an industry-recognised training course followed by assessment of competence. Training that leads to assessment of competence in safe gas work should be recognised by the industry's standards setting body, or
- b) in the case of a currently or previously Gas Safe registered person, where they have proved competence through a certification scheme; or
- c) for those working at premises that fall outside the scope of the Gas Safety (Installation and Use) Regulations 1998 (GSIUR) as amended (see regulation 2(4) and associated guidance), by a person who has successfully completed an appropriate full training course followed by assessment of competence.

For further information, please visit www.euskills.co.uk/.

All businesses and individuals undertaking gas work on installations supplied with Natural gas or LPG must be registered with a body approved by the Health and Safety Executive (HSE). In the United Kingdom, the Isle of Man and Guernsey at the time of publication, the only body with approval to operate and maintain a register of individuals/businesses who are "members of a class of persons" is Gas Safe Register. Thus, it is essential that all businesses or self-employed gas engineers are registered with Gas Safe Register.

All gas appliances and other gas fittings must be installed in accordance with the GSIUR, relevant Building Regulations and manufacturer's installation instructions. Installation guidance published by product manufacturers may be deemed 'appropriate standards' within the meaning of the GSIUR, provided that the technical specification/guidance provides, in use, equivalent levels of safety, suitability and fitness for purpose to those achieved by the relevant standard(s) to which it is expressed to be equivalent. Installations should also comply with relevant British Standards and other recognised Codes of Practice.

Only the components provided or specified by OmegaFlex® as part of the approved piping system are to be used in the installation. The use of TracPipe® and TracPipeCC® piping or fittings with piping or fittings from other gas piping manufacturers is strictly prohibited and may result in serious bodily injury or property damage.

If this system is used or installed improperly, fire, explosion or asphyxiation may result. The installation instructions and applicable Regulations and British Standards must be strictly followed.

OmegaFlex Ltd

Kildare House, Wildmere Road,
Banbury, Oxon
OX16 3JU
U.K.

Tel: 01295 676670

Fax: 01295 267302

Eurosales@omegaflex.com

Tech-Help@omegaflex.com

www.tracpipe.co.uk

OmegaFlex, INC

451 Creamery Way,
Exton, PA 19341
USA

Tel: +1 610 524-7272

Fax: +1 610 524-7282

www.omegaflex.com

Foreword

Relevant Installation Standards

EN 15266: 2007 and its relevance to the now withdrawn BS 7838.

When British Gas had a monopoly on all gas matters in the UK they developed a number of in-house procedures and product standards to ensure the safety of installations. As the gas installation market opened to more registered installers, the majority of the in-house documents formed the basis either of British Standards or of Institution of Gas Engineers & Managers (IGEM) Standards.

The design and installation of low-pressure gas pipework in domestic sized premises is specified in BS 6891, whilst pipework with larger bore sizes and higher operating pressures in industrial and commercial premises is covered in IGEM/UP/2 Latest Edition. Strength testing, tightness testing and purging of installation pipework are covered in the IGE/UP/1 standards.

As natural gas was being introduced as a fuel gas in the UK, British Gas had concerns about the reaction of sulphur compounds with the existing installation pipework (generally referred to as “black dust”). As a consequence, they researched alternative, resistant pipework materials and conducted trial installations with stainless steel semi-rigid pipework. This resulted in an in-house standard that formed the basis for BS 7838, first published in 1996 and incorporated into the design and installation standards in 1998. Also in 1998, the Gas Safety (Installation and Use) Regulations were adopted and provided for a uniform set of rules regarding the safe installation of gas piping.

EN 15266 had been written in response to a CEN work item under the then Construction Products Directive (CPD) to permit the use of stainless steel pliable tubing kits in fuel gas installations across the European Member States. The installation standards for fuel gases tend to be unique to each European country, as is the case in the UK.

BS EN 15266:2007 is the UK implementation of EN 15266:2007. The UK participation in the preparation of EN 15266 was entrusted to Technical Committee PSE/12, *Metal hoses, hose assemblies, bellows and expansion joints*. The only European countries represented on this committee with CSST market experience and CSST technical experience at that time were the UK and Ireland. In addition the UK was the only country with a national standard, which was BS 7838. However, the resulting draft standard proposed by the European committee CEN/TC 342/WG3 did not include or reference that guidance. It soon became evident that EN 15266 was deeply flawed and inadequate in many regards, and that for the UK a detailed forward was needed to note the deficiencies and deviations of EN 15266 to current British codes and standards.

BSI formed a joint committee combining GSE/1 and PSE/12 to review both documents with the specific purpose of producing a UK foreword to BS EN 15266. This work was extensive and took several years but this was never published by BSI. The responsibility now sits with committee GSE/42, which combined both GSE/1 and PSE/12.

EN 15266 has not been harmonized; it has not been published in the Official Journal of the European Union (OJEU). Therefore it is not possible to “CE” mark product.

In August 2019, BSI made the decision to withdraw BS 7838 despite opposition from several manufacturers sitting on the GSE/42 Technical Committee, including OmegaFlex®. In the lead up to the withdrawal of BS 7838, it became apparent that EN 15266 did not cover certain installation applications, such as external use and direct burial, and that other European countries within the CEN/TC 342/WG3 had serious concerns over the robustness of EN 15266 because of those limitations and other issues. As a result of the withdrawal of BS 7838, the UK market is now open to CSST products that may not be suitable for all application requirements in the UK. At the time of publication of this Specification, although work has started on a revision of EN 15266, the drafting and approval work is likely to take several years to complete leaving a significant safety related gap in the UK market.

In the meantime TracPipe® retains kitemark licence BS EN 15266.

Summary

CSST systems previously tested and Kitemarked to the now withdrawn BS 7838 (such as TracPipe®) will almost certainly meet the test requirements of BS EN 15266.

CSST systems tested to meet the requirements of EN 15266 don't necessarily meet the full test requirements of the recently withdrawn BS 7838, and may not comply with the requirements for UK installation practices.

Table of Contents

| | |
|---|----|
| 1 - Scope..... | 6 |
| 2 - References | 7 |
| 3 - Definitions..... | 7 |
| 4 - Design and planning..... | 8 |
| 5 - Pipe Sizing | 9 |
| 6 - Materials | 10 |
| 7 - Autoflare® Fittings | 13 |
| 8 – Installation..... | 19 |
| 9 - Corrosion..... | 49 |
| 10 - Testing for Gas Tightness, Purging and Confirmation of Adequacy of Pipework..... | 50 |
| 11 – Damage and Repair | 52 |
| 12 – TracPipe® and TracPipeCC® System Components | 53 |
| Annex A – Essential Information (Normative) | 58 |
| Annex B – Guide to Sizing Gas Supplies (Normative)..... | 59 |
| Annex C – Definitions (Informative)..... | 63 |
| Annex D – Sample Specification (Informative) | 65 |
| Annex E – Pipe Cutter and Secondary Containments (Informative)..... | 66 |
| Annex F – Sizing Tables for TracPipe® and TracPipeCC® (Informative) | 67 |

1 - Scope

TRACPIPE®: BSI Assurance has issued Kitemark Licence Number KM 549666 to OmegaFlex® for all sizes of TracPipe® which are in conformity with BS EN 15266 *Stainless steel pliable corrugated tubing kits in buildings for gas with an operating pressure up to 0,5 bar.*

This Kitemark Licence covers TracPipe® sizes DN12, 15, 22, 28, 32, 40 and 50 and their associated fittings.

BS EN 15266 specifies requirements for the requirements for material, design, manufacture, testing, marking and documentation of stainless steel pliable corrugated gas tubing kits for buildings with a maximum operating pressure (MOP) less than or equal to 0,5 bar and a nominal size range from DN 10 to DN 50. This document applies to stainless steel pliable corrugated gas tubing kits used for 1st, 2nd and 3rd family gases in residential, commercial and industrial gas installations.

BS EN 15266 does not adequately meet the requirements for certain UK installation requirements (such as exterior use, direct burial both internally and externally and use within fire protected areas) and therefore TracPipe® is still manufactured to meet the robust requirements of the recently withdrawn BS 7838, which is the preferred choice of OmegaFlex Ltd.

TracPipe® meets all of the requirements for exterior use, direct burial (both internally and externally) and use within fire protected area and can be installed in accordance with BS 6891: 2015 in premises (domestic and some small commercial), or in accordance with the Institution of Gas Engineers and Managers publication IGEM/UP/2 Latest Edition in other premises.

TRACPIPECC®: TracPipeCC® does not currently fall under the Kitemark licence issued for TracPipe®. TracPipeCC® has been independently assessed by BSRIA and confirmed that when tested, TracPipeCC® performed as designed. Copies of the BSRIA Summary Report can be obtained by emailing tech-help@omegaflex.com

This document contains portions of BS 6891 language where appropriate, (for which we are grateful to BSI), which is the *Specification for the installation and maintenance of low pressure gas installation pipework of up to 35mm (R1¼) on premises.* This standard applies to gas installation pipework where the nominal working pressure is 21mbar for Natural gas, 37mbar for Propane and 28mbar for Butane.

The installation of pipework in sizes above DN32 (35mm) and working pressures above those covered by BS 6891 falls under the Institution of Gas Engineers and Managers Utilization Procedures IGEM/UP/2 *Installation pipework on industrial and commercial premises* Latest Edition.

TracPipe® has North American approvals for working pressures to 125psi (8.6bar) and we would be pleased to discuss potential applications for working pressures in excess of 500mbar outside the scope of this Design and Installation Specification.

Sound engineering principles and practices must be exercised for the proper design of fuel gas piping systems, in addition to compliance with the Gas Safety (Installation and Use) Regulations 1998 as amended, Building Regulations and with British Standards requirements. The installation instructions and procedures contained in this Specification must be strictly followed in order to provide a safe and effective fuel gas piping system or system modification.

This Specification is intended to aid the Gas Safe registered engineer in the design, installation and testing of the TracPipe® and TracPipeCC® semi-rigid gas piping systems.

It is not possible for this specification to anticipate every variation in construction style, building configuration, appliance requirement, or local restriction. This document will not therefore cover every application. The user should contact us, exercise their own engineering judgment on system design and installation, or seek technical input from other qualified sources. Additional information pertaining to gas piping systems is available from IGEM, Gas Safe Register and your local gas utility.

2 - References

| | |
|---------------------------------------|---|
| BS EN 15266 | Stainless steel pliable corrugated tubing kits in buildings for gas with an operating pressure up to 0,5 bar |
| BS 6891 | Specification for the installation and maintenance of low pressure gas installation pipework of up to 35 mm (R1¼) on premises |
| BS 8313 | Code of practice for Accommodation of building services in ducts |
| IGEM/UP/2 Latest Edition | The Institution of Gas Engineers and Managers, Installation pipework on industrial and commercial Premises. |
| IGEM/UP/7 Latest Edition | Gas installations in timber framed and light steel framed buildings |
| IGEM/UP/11 Latest Edition | Gas installations for educational establishments |
| IGEM/G/5 Latest Edition | Gas in multi-occupancy buildings |
| UKLPG COP22 Latest Edition | Design, Installation and Testing of LPG Piping Systems |

3 - Definitions

See Annex C.

4 - Design and planning

4.1 Exchange of information and time schedules

4.1.1 At the initial stages of building design and planning it needs to be verified that the pipework will be adequate for the known requirements.

4.1.2 All necessary information regarding the routing of pipework and positions of valves and termination points to serve the appliances need to be made available by means of drawings, specifications and consultations, as appropriate.

Note: Any drawings should include:

- a) the position of voids, shafts, ducts, and channels when pipework is to be concealed;*
- b) special requirements of a precautionary nature, e.g. limitations on proximity to other services or effects of differential movement due to the building construction; and*
- c) sizes, materials and position of all pipework and fittings.*

5 - Pipe Sizing

- 5.1 When designing an installation, the sizes of all installation pipework should ensure the gas is at a suitable pressure at the inlet of any connected gas appliance to ensure that it meets the required appliance heat input. Where any sections of the pipework supply gas to multiple appliances, the heat input of all appliances fed by that section of pipework needs to be taken into account (see also Clause 10.2 for commissioning of installation pipework). The example method of calculating pipe sizes in Annex B can be used in conjunction with the appropriate Tables in Annex F.
- 5.2 The design maximum pressure loss for all pipework must not exceed that specified in Clause 5.5 or Clause 5.6 in the following circumstances.
- a) New installations
 - b) Pipework modification or extension to existing installations
 - c) Before any new appliance is fitted to a new or existing installation
 - d) Increasing any appliance heat input
- 5.3 For range-rated appliances (see Annex C – Definitions), the installer must use the maximum heat input to ensure the pipework is sized correctly.
- 5.4 For variable-rated appliances (see Annex C – Definitions), the installer must establish the heat input necessary to meet the requirements of the system and shall use this value to ensure the pipework is sized correctly.
- 5.5 For natural gas at 21mbar the maximum design pressure drop between the outlet of the meter and any connected appliance should not exceed 1mbar at design installation flow conditions.
- 5.6 Low pressure 3rd family gas supplies should be regulated at 37mbar (propane) or 28mbar (butane) with a maximum design pressure drop not exceeding 2mbar from the outlet of the primary meter installation, or where no meter is installed, the outlet of the Emergency Control Valve (ECV) or the outlet of the final stage regulator when fitted after the ECV and the point to be connected on any appliance.

6 - Materials

6.1 General

Materials used for gas installation pipes and fittings shall conform to the British Standards listed in 6.2 to 6.7 where appropriate.

6.2 Pliable corrugated stainless steel tube

Pliable corrugated stainless steel tube shall conform to BS EN 15266.

See section 6.7 for details of the TracPipe® and TracPipeCC® corrugated stainless steel piping system.

6.3 Steel

Steel pipe nipples may be used in TracPipe® and TracPipeCC® installations for attachment to appliances, valves and other accessories. All steel pipe material shall conform to:

- BS EN 10255;
- BS EN 10216-1 and BS EN 10217-1 and/or BS EN 10216 2;
- BS EN 10217-2.

Steel fittings shall conform to BS EN 10241.

6.4 Malleable iron

Malleable iron fittings may be used in TracPipe® and TracPipeCC® installations for attachment to appliances, valves and other accessories.

Malleable iron fittings shall conform to:

- BS 143 and 1256; and/or
- BS EN 10242

6.5 Valves

Valves shall conform, as appropriate, to:

- BS EN 331; or
- PRS1/E; or
- GIS/V7-3; or
- BS 1552.

Lubricants used in valves need to be of a type suitable for use with the gas.

For LPG installations, plug valves need to be spring-loaded.

6.6 Thread sealing

Sealing materials shall conform to BS EN 751 Parts 1-3 as appropriate. Jointing compound is prohibited on the internal sealing components of the AutoFlare® fitting (see Clauses 7.1.4 and 7.4).

6.7 TracPipe® and TracPipeCC® corrugated stainless steel tube

6.7.1 The TracPipe® and TracPipeCC® gas piping systems consist of corrugated, semi-rigid stainless steel piping with AutoFlare® brass mechanical attachment fittings terminating in a male BSP taper thread, a female BSP thread or a copper compression connection for easy attachment to rigid steel or copper pipe systems and connections to fixed gas appliances. The tubing is

jacketed with a yellow polyethylene cover, with UV and Ozone protection as well as smoke and fire retardant properties (EUROCLASS Reaction to Fire Classification B – s1, d0), which provides ease of running through building components. The cover is tested to operate at temperatures of up to 95°C ambient so can be used in areas with elevated temperatures, such as commercial catering environments. The cover is also marked at one-metre intervals with the amount of tubing left on the reel, for quick measurement.

The yellow colour is the international designation for fuel gas.

TracPipe® and TracPipeCC® are designed to replace or use as an alternative to rigid copper or steel pipework between the meter (or ECV for LPG installations) and appliance. It is not intended for applications in which during installation, or subsequent to installation, it can be subjected to repeated bending or vibration. TracPipe® and TracPipeCC® must not be used as a flexible connector to a movable appliance (see Annex A).

TracPipe® and TracPipeCC® meet all test requirements of both the recently withdrawn BS 7838 and BS EN 15266 including the Bending performance test (BS EN 15266 - Clause 5.4). This stipulates 12 repeat bends through 180 degrees around a cylindrical former. The cylindrical former radius is equivalent to the Minimum Bend radius for that size of TracPipe®/TracPipeCC® (see Table 1). The bend radius should be measured at the centre of the pipe (see Figure 1).

Table 1. Bend radii for TracPipe® and TracPipeCC®

| TracPipe® and TracPipeCC® Size DN | Bend radius | |
|---|-------------------|---------------|
| | Recommended mm | Minimum mm |
| 12 (TracPipe® only) | 76 | 15 |
| 15 | 76 | 25 |
| 22 | 76 | 25 |
| 28 | 125 | 76 |
| 32 | 125 | 76 |
| 40 | 125 | 76 |
| 50 | 150 | 102 |

Figure 1: Measurement of bend radius

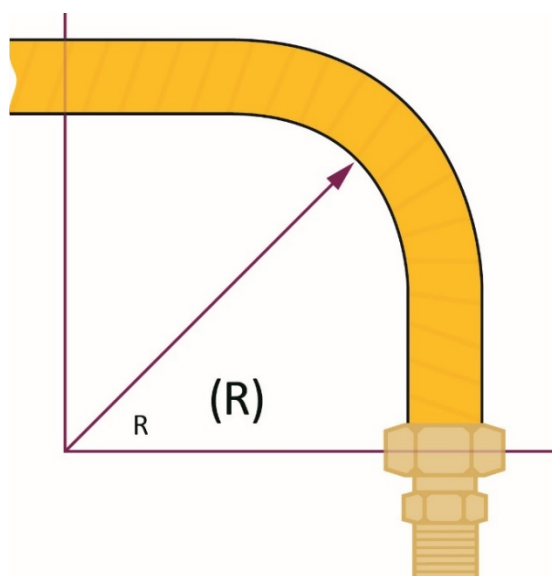

- 6.7.2 Tee fittings are available for addition of branch lines into tubing runs.
- 6.7.3 Protection Devices are used where thin walled piping passes through building materials and is restricted from moving to avoid nails, screws, drills and other puncture threats. There are four striker plate configurations made from stamped steel and specially hardened to resist penetration from screws and pneumatic nail guns. In addition, spiral wound steel “floppy” conduit is available for additional protection in areas where striker plates cannot be used.
- 6.7.4 Bending TracPipe® and TracPipeCC® is one feature that contributes to the speed of installation. The recommended and minimum bend radius for general routing is listed in Table 1.

Multiple tight bends can restrict the gas flow and increase overall pressure drop (see Annex B and Annex F).

Typical locations requiring tight bends are when passing through walls.

7 - AutoFlare® Fittings

7.1 How to Assemble Fittings to TracPipe® and TracPipeCC®

7.1.1 Cut-to-Length

Determine proper length. Cut through outer cover and stainless pipe using a tube cutter with a sharp steel wheel that is large enough to reach the bottom of the corrugation. Cut must be centred between two corrugations. Use full circular strokes in one direction and tighten roller pressure slightly (a quarter turn) after each revolution. **DO NOT OVERTIGHTEN ROLLER**, which may flatten pipe.



7.1.2 Strip Cover

Using a utility knife, strip back the outer cover about 25mm back from the cut end to allow assembly of fittings. *Caution: Knife blade and cut pipe ends are both sharp. Use care when cutting the cover and handling the pipe.*



7.1.3 Install Back Nut

Slide the back nut over the cut end; place the two split rings into the first corrugation next to the pipe cut. Slide the back nut forward to trap the rings.



7.1.4 Fit AutoFlare® Fitting

Place the AutoFlare® fitting into the back nut and engage threads. Note that the AutoFlare® fitting is designed to form a leak tight seat on the stainless piping as you tighten the fitting. (The piloting feature of the insert will not always enter the bore of the piping before the tightening operation, but will centre the fitting when tightened). **Jointing compound is prohibited on the internal sealing components of the AutoFlare® fitting (see Clause 7.4).** Using appropriate wrenches, tighten the fitting until insert bottoms and the resistance to wrenching increases greatly. The flare has now been created on the piping end.

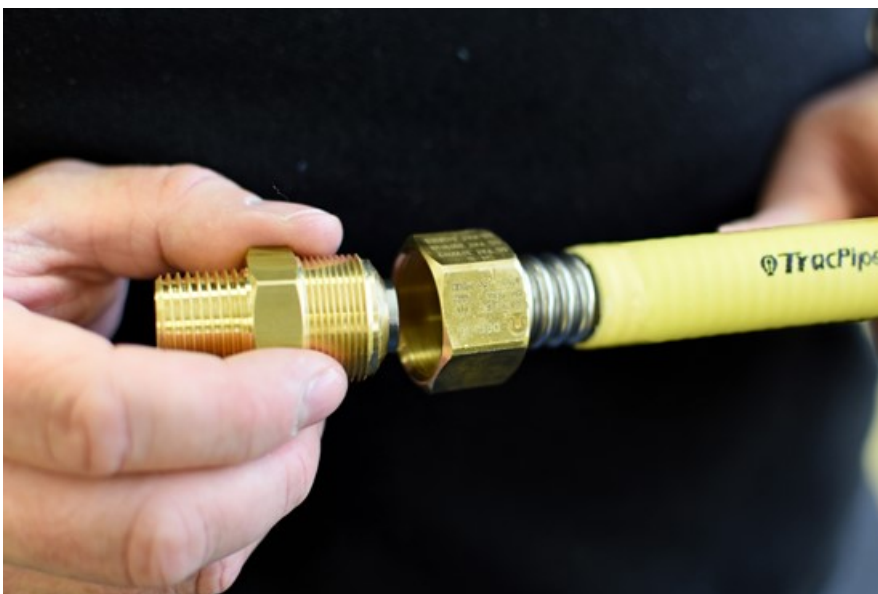

7.1.5 Final Torque

Tighten nut and body as though you were making up a flared tubing joint. Note the relation between hex flats at this point and continue to tighten for two additional hex flats (one-third turn) to obtain required torque and final leak-tight metal-to-metal seal.



Torques for sealing are:

| DN | Torque N.m | Ft.lbs |
|----|------------|-----------|
| 12 | 54 | 40 |
| 15 | 57 | 42 |
| 22 | 61 | 45 |
| 28 | 100 | 75 |
| 32 | 200 - 270 | 150 - 200 |
| 40 | 270 - 340 | 200 - 250 |
| 50 | 340 - 405 | 250 - 300 |

7.1.6 Tape Wrap

AFTER GAS TIGHTNESS TEST - Care must be taken after pressure test to ensure that no stainless steel pipe is visible.

Any portions of exposed stainless steel behind the fitting nut shall be wrapped with self-amalgamating silicone tape TracPipe® P/N FGP-915-10H-12, (25 mm wide), or FGP-915-20H12PO, (50mm wide).

For all fittings other than couplings, the first wrap of tape should occur on the exposed stainless steel pipe next to the fitting nut, stretched very tightly, and wrapped with a 55% overlap onto the outer cover for 50mm. The tape should then be wrapped back over the first layer, over the fitting nut and up to the edge of the shoulder of the fitting. This will allow a section of the fitting to still be accessible for the application of any electrical bonding clamp that may be required (see Clause 8.15.5.3). If an electrical bonding clamp is not required, it is acceptable to cover the entire fitting with tape if required.

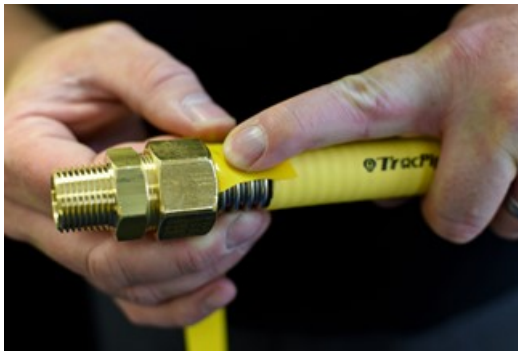

Start the tape wrap immediately behind the back nut on the exposed stainless steel



With the tape stretched very tightly wrap onto the outer cover



The tape should then be wrapped back over the first layer, over the fitting nut and up to the edge of the shoulder of the fitting

For couplings, the first wrap of tape should occur on the exposed stainless pipe next to the fitting nut, stretched very tightly, and wrapped with a 55% overlap onto the outer cover for 50mm. The tape should then be wrapped back over the first layer, over the coupling and 50mm onto the outer cover on the opposite side of the coupling. Continue back towards the second side of the coupling ending just behind the nut. It is unlikely that an earthing bond clamp will need to be applied to a coupling and therefore it is acceptable to cover the entire fitting with tape.

This will reduce the possibility of later external corrosive attack.



Example of a fully wrapped coupling

7.2 Additional Requirements for TracPipeCC®

ACCESS PULLING CORD: After cutting TracPipeCC® to the correct length, find the location of the red pulling cord at the cut end. Using a utility or cable knife, cut into the cover (max 25mm) so the cord can be pulled away from the pipe. Using a pair of pliers pull the cord out from the cover and down the length of the pipe for approximately 200mm (the cord will cut the outer secondary cover only). Starting at the top of the open cut, gently pull the outer secondary cover away from the internal primary cover.

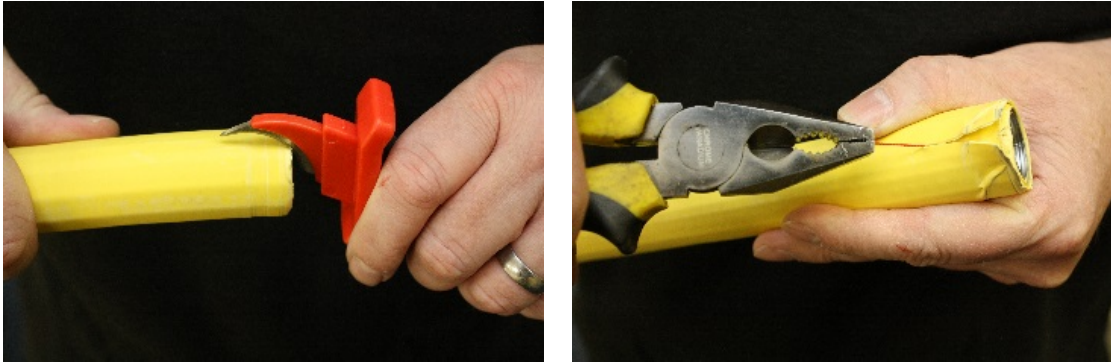

SCORE AROUND CIRCUMFERENCE OF PIPE: Use a utility or cable knife to lightly score around the circumference of the pipe. **DO NOT FULLY PENETRATE THE OUTER COVER WITH THE KNIFE BLADE**



REMOVE OUTER COVER: Following the score around the circumference of the pipe, fully remove the section of outer secondary cover. Closely inspect the internal primary cover to ensure it has not been penetrated adjacent to the outer secondary cover. Cut off any excess cord exposed when the cover has been removed.



Once these steps have been completed, follow the remaining steps from Clause 7.1.2.

7.3 Screwed joints

Malleable cast iron and cast copper alloy fittings can be used in conjunction with the TracPipe® and TracPipeCC® systems, in which case they shall conform to BS 143, BS 1256 or BS EN 10242. All threads shall be clean prior to the application of any thread sealing material.

7.4 Jointing compounds, tapes and cords

Jointing compounds, tapes or cords are prohibited on the internal sealing components of the AutoFlare® fitting.

These components are designed for metal-to-metal sealing without the aid of jointing compounds, tapes or cords. The use of jointing compounds, tapes or cords on flared sealing faces of this fitting can interfere with proper assembly and cause leakage.

When jointing compounds, tapes or cords are used, it should only be applied to the external pipe threads and any excess paste should be removed on completion of the joint. Jointing compound should not be used in conjunction with PTFE tape or cords.

Jointing compounds, tapes and cords should be applied in accordance with the manufacturer's instructions.

7.5 AutoFlare® fittings shall not be buried in the structure or below ground and shall remain readily accessible in an appropriately ventilated space.

8 – Installation

8.1 General

- 8.1.1 Installation pipework shall be physically protected or located where it is not liable to mechanical damage. The bore of an installation pipe should not be restricted by kinks, burrs, or foreign matter or in any other way.
- 8.1.2 Pipework needs to be installed so it will not impair the structural stability, fire resistance, damp proof course, or thermal and sound insulation of a building. The pipework should be situated such that gas is not capable of entering cavities in the event of a gas escape.
- 8.1.3 Pipework must not be installed in any location where, should there be a requirement to gain access to the pipe in the future, this could affect the structural stability of the building (for example within a structural screed or topping or within a structural timber floor).
- 8.1.4 For LPG installations, pipework entries to, and exits from buildings shall always be above ground.
- 8.1.5 AutoFlare® fittings shall not be buried in the structure or below ground.

8.2 Safety precautions

- 8.2.1 Prior to any work being undertaken on the pipework installation, a risk assessment should be undertaken. This will need to include:
- risks involved in working on installations that contain fuel gas;
 - stray electrical currents.
- 8.2.2 Suitable precautions shall be taken to determine the possibility of stray electrical voltages being present.
- Note:** *A non-contact voltage detector (single pole) capable of indicating voltages of 50 V or greater used on all exposed metalwork in the work area assists in the detection of stray voltage that might be harmful.*
- 8.2.3 While installation work is in progress, care needs to be taken to prevent the ingress of dirt, water, etc., into installation pipes. Where the installation pipework is connected to a gas supply, the open end should be correctly sealed using an appropriate fitting such as a plug or cap. If the pipework is not connected to a gas supply, then the ends should be sealed to prevent the ingress of dirt and this may be by the means of plastic caps, etc.
- 8.2.4 Where work is in progress on pipes already connected to a meter either:
- a) the meter shall be temporarily disconnected and both the open ends of the pipework sealed and dust caps fitted to the meter; or
 - b) all open ends of the pipework shall be plugged, capped or terminated with a self-sealing appliance connector conforming to BS 669-1, BS 669-2, BS EN 14800 or BS EN 15069 as appropriate, before the work is left unattended.

Installers need to consider the risk of persons restoring the gas supply at the primary meter should they leave the general location where the work is in progress.

- 8.2.5 When work has been completed, open ends of pipe shall be plugged, capped or terminated with a self-sealing appliance connector conforming to BS 669 -1, or BS 669 - 2, BS EN 14800 or BS EN 15069 as appropriate.

- 8.2.6 Before any work is carried out on an installation, where there is a risk of any gas within the pipework being ignited and constituting a danger (for example, when using a blowlamp) the following precautions shall be taken:
- Carry out a gas tightness test in accordance with IGEM/UP/1, IGEM/UP/1A or IGEM/UP/1B, as appropriate, on the installation, or section of the installation, in particular to verify that there is no let-by from the valve used to isolate the gas supply. Where a gas escape or let-by is found, this should be rectified before proceeding.
 - Disconnect the gas supply to the installation, or section of the installation.
 - Remove any meter, where fitted, from the installation, or section of the installation.
 - Immediately seal all exposed gas ways, for example, open ends on the pipework and/or meter, with an appropriate fitting.
 - Increase natural ventilation in the work area where possible.
- 8.2.7 The open ends of pipework connected to the gas supply and of any gas meter shall be plugged or capped.
- 8.2.8 Naked flames shall be kept away from the open ends of pipework.
- 8.2.9 In no case shall oxy-gas flame cutting equipment be applied to any meter, pipe or fitting containing gas.

8.3 Connection and disconnection of pipes and fittings

- 8.3.1 Where any installation pipe is no longer required, the pipe(s) must be disconnected as close to the point of supply as practicable. All pipe ends must be sealed with an appropriate fitting, e.g. with a plug or cap.
- 8.3.2 During any work that necessitates connection or disconnection of any installation pipework, a temporary continuity bond needs to be securely fixed to the pipework either side of the intended connection or disconnection, whether or not permanent equipotential bonding has been established.

The recommended disconnection procedure is typically as follows:

- Isolate the electrical connection of associated gas appliances from the electricity supply.
- Clip or clamp a temporary continuity bond to each side of the union, fittings or complete section that is to be removed or connected ensuring that good metallic contact is made.
- Leave the bond in position until after the work is completed and metallic continuity re-established. Where pipework is to be removed, ensure that both sections of pipework left are bonded before removing the temporary electrical continuity bonding conductors.

Note: A temporary continuity bond would typically comprise of at least 1.2m of single-core insulated flexible cable or equivalent of at least 250 V rating. The cable should have a cross-sectional area of not less than 10mm² and multi-strand flexible construction generally in accordance with BS 6004, BS 6007 or BS 6231 with a robust clip or clamp firmly attached at each end.

8.3.3 TracPipe® and TracPipeCC® can be connected directly to a gas meter outlet providing the meter is securely restrained (e.g. by a meter bracket fastened to the floor/wall). Where the gas meter is not securely restrained, the connection to the meter installation shall be in securely fixed rigid pipework for at least the first 600mm before transition is made to TracPipe® or TracPipeCC®.

8.4 TracPipe® and TracPipeCC® laid in joisted floors and roof spaces (including compartment floors)

8.4.1 Where TracPipe® or TracPipeCC® is installed in joisted floors and roof spaces it must run either in the direction of the joists, or at 90° to the joist direction. Diagonal runs of TracPipe® or TracPipeCC® must not be installed.

8.4.2 Where TracPipe® or TracPipeCC® is installed between floor joists or roof spaces, it should be correctly supported in accordance with Clause 8.12. These maximum intervals for pipe support also apply to surface mounted pipework.

TracPipe® and TracPipeCC® is not annealed after forming to ensure maximum hoop strength and resistance to external damage. As such it has a lower tendency to sag than annealed products.

8.4.2 Where TracPipe® or TracPipeCC® is laid across the joists in ceiling or roof spaces fitted with flooring they need to be located in purpose-made notches or circular holes. Care must be taken when notching or drilling joists to ensure the structural strength of the joist is not impaired.

Note: Detailed guidance on the notching and drilling of joists can be found in BS 6891.

Recommended drill hole sizes for TracPipe® and TracPipeCC® can be found in Table 2.

Table 2. Drill hole sizes for TracPipe® and TracPipeCC®

| TracPipe® Size (DN) | Drill hole size (mm) | TracPipeCC® Size (DN) | Drill hole size (mm) |
|---------------------|----------------------|-----------------------|----------------------|
| 12 (TracPipe® only) | 28 | N/A | N/A |
| 15 | 35 | 15 | 38 |
| 22 | 38 | 22 | 44 |
| 28 | 45 | 28 | 51 |
| 32 | 57 | 32 | 57 |
| 40 | 64 | 40 | 64 |
| 50 | 76 | 50 | 86 |

8.4.3 The flanges of timber-engineered joists and metal web joists must not be notched, drilled, altered or damaged.

8.4.4 Where TracPipe® or TracPipeCC® is installed at 90° to timber-engineered joists with I-beam construction or laminated timber joists with a rectangular cross section, it should be installed through the web of joists in accordance with the joist manufacturer's guidance.

8.4.5 Where TracPipe® or TracPipeCC® is installed at 90° to metal web joists with timber flanges, it needs to pass between the metal webs with pipework supported on the wooden flanges and not in contact with the metal structure of the joist.

Where TracPipe® or TracPipeCC® is installed at 90° to metal web joists with metal flanges, it needs to pass between the metal webs with pipework supported in such a manner that it is not in direct contact with the metal of the joist structure.

Note: *TracPipe® and TracPipeCC® are particularly suitable for this system of joists as they can be threaded between joists with ease. Prior to running pipework below suspended floors a visual inspection should be carried out to note the position of any electrical cables, junction boxes and ancillary equipment, in order that accidental damage or injury does not occur when inserting pipework.*

- 8.4.6 Care should be taken when re-fixing flooring to prevent damage to the pipework by nails or screws. Where possible, the flooring should be appropriately marked to warn others of the pipework below the flooring.
- 8.4.7 Where TracPipe® is installed within an intermediate joisted floor or in a void under a floor, unless there is sufficient adventitious ventilation available, ventilation will need to be provided in accordance with Clause 8.8, Table 3. For LPG and LPG/air mixtures this ventilation shall be at the lowest point. Alternatively, TracPipeCC® can be used (see 8.8.3) or, the TracPipe® can be contained within a vented duct where it passes through the void (Annex E).
- 8.4.8 Pipework shall not be installed within any fire compartment floor that separates one dwelling from another part of the building, except as shown in Figure 2 and Figure 3.

Figure 2 Gas pipework in concrete compartment floors

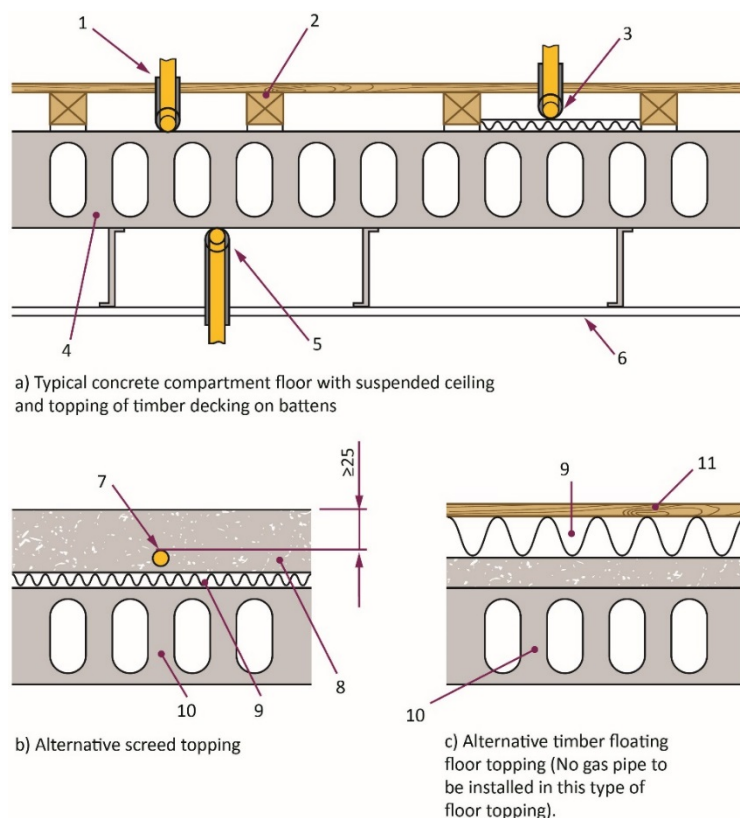

Key to Figure 2

1. Gas pipe within vented ducting extended above floor level. Sealed to floor deck with flexible sealant
2. Floor decking on resilient battens on bearers/pads
3. Ducted gas pipe can be above or below any resilient quilt laid between floor with no fixings used to secure the ducting penetrating or damaging the quilt
4. Structural floor slab
5. Gas pipe within vented ducting located within suspended ceiling void and sealed to ceiling board
6. Suspended ceiling
7. TracPipe® / TracPipeCC® laid directly in screed above resilient overlay
8. Non-structural screed or topping
9. Resilient sound-proofing board
10. Structural floor slab
11. Floating floor

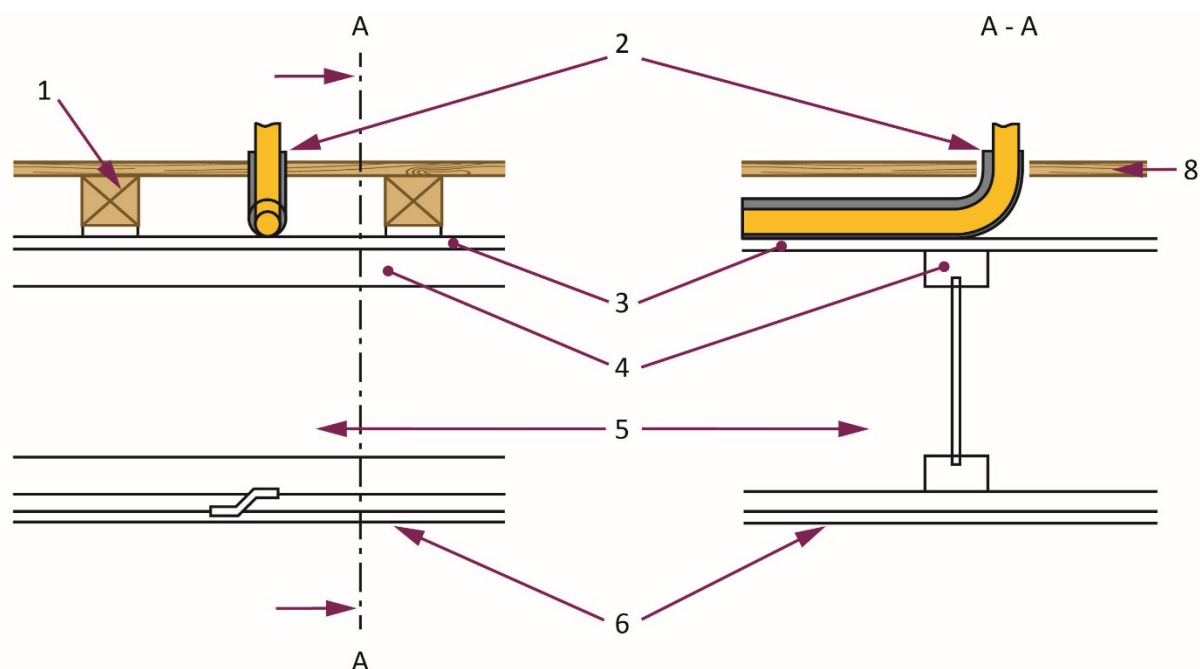
Figure 3 Gas pipework in timber fire compartment floors

a) Typical suspended timber compartment floor

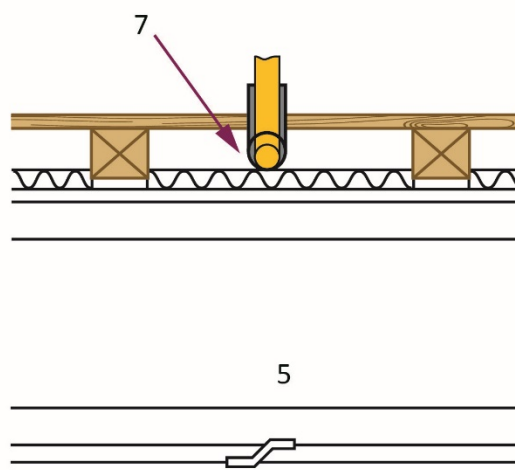

b) Typical suspended timber compartment floor incorporating resilient quilt

Key to Figure 3

1. Floor decking on battens on resilient bearers/pads
2. Gas pipe within vented ducting extended above floor level and sealed to floor deck with flexible sealant
3. Structural deck
4. Timber joist
5. No gas service in this void
6. Ceiling fixed to resilient bars
7. Ducted gas pipe can be above or below any resilient quilt laid between floor battens with no fixings used to secure the ducting penetrating or damaging the quilt
8. Floor deck

8.5 Pipes laid in solid floors

- 8.5.1 TracPipe® and TracPipeCC® must not be buried in structural elements of the floor, such as concrete slabs or structural toppings.

Where TracPipe® or TracPipeCC® is to be installed in solid floors it must run parallel or at 90° to the walls.

TracPipe® and TracPipeCC® must not be buried in power-floated floors that form part of the structure.

TracPipe® and TracPipeCC® should only be installed in an acoustic floor with the agreement of the building designer.

Pipework that is to be buried in a solid floor shall be suitably protected against corrosion and degradation.

Where pliable corrugated (stainless steel) tube is to be buried in floor screed (including magnesium-oxy-chloride cement or magnesite flooring), it shall be:

- a) directly buried pliable corrugated (stainless steel) tube which:
 1. the manufacturer's instructions specifically allow direct burial;
 2. is installed in accordance with the manufacturer's instructions; and
 3. has a factory-applied cover with a minimum thickness of 0.5mm, manufactured from a non-chlorinated material of a synthetic polymer or elastomer with a total chloride content not exceeding 50ppm; or
- b) laid inside a buried outer pipe conforming to 8.7 *Sleeves* or a covered channel which terminates either above floor level or with suitable inspection points which permit periodic inspection.

TracPipe® (Kitemarked to BS EN 15266) is manufactured to the requirements of the recently withdrawn BS 7838 and therefore meets the requirements for direct burial including the minimum thickness of outer cover and the maximum allowable chloride content. TracPipeCC® is also suitable for direct burial as the secondary cover provides additional protection and is above that required by the installation standard. Products manufactured to BS EN 15266 only may not meet the above requirements for minimum thickness of cover and maximum chloride content as they do not form part of the BS EN 15266 manufacturing requirements.

TracPipe® and TracPipeCC® laid in solid floors must be installed in accordance with Figures 4a, 4b and 4c.

Where TracPipe® or TracPipeCC® is buried in a non-structural floor screed there needs to be a minimum of 25mm of cover above the pipework for domestic installations and a recommended minimum depth of cover of 40mm for industrial and commercial installations.

- 8.5.2 After TracPipe® or TracPipeCC® is installed and prior to pouring screed, the entire run of pipework must be examined visually and manually. The installer must closely inspect the cover over the entire length to check for any damage or voids in the yellow polyethylene cover, which could affect corrosion resistance. Repair any damage by wrapping with tape in accordance with Section 11. Tape wrapping must be done with self-amalgamating silicone tape TracPipe® P/N FGP-915-10H-12, (25mm wide), or FGP-915-20H12PO, (50mm wide).

8.5.3 Pipes laid in non-structural toppings of floors shall be protected against failure caused by movement.

TracPipe® and TracPipeCC® are suitable to withstand seismic movement and settlement.

TracPipe® and TracPipeCC® are fitted with a polyethylene covering material, which is soft yet thick enough to provide movement and resilient enough to support the screed or non-structural topping while it is setting.

8.5.4 Pipes passing vertically through solid floors shall take the shortest practicable route and shall be sleeved (see Clause 8.7).

8.5.5 AutoFlare® fittings shall not be buried in the structure or below ground.

8.6 Pipes in walls

8.6.1 Pipe runs

TracPipe® and TracPipeCC® runs shall, where possible, be vertical and shall be placed in ducts with convenient access points or placed in pipe chases. Typical methods of installing TracPipe® and TracPipeCC® in walls are shown in Figure 5. TracPipe® and TracPipeCC® should be secured at each floor.

8.6.2 Plaster walls

In plaster walls, (see Figures 5a and 5b) examine the entire run of pipework visually and manually to check for any damage or voids in the yellow polyethylene cover. Repair any damage as described in Clause 8.5.2 with TracPipe® self-amalgamating silicone tape.

Figure 4a Typical examples of internally buried pipework (Ground Bearing Concrete floors)

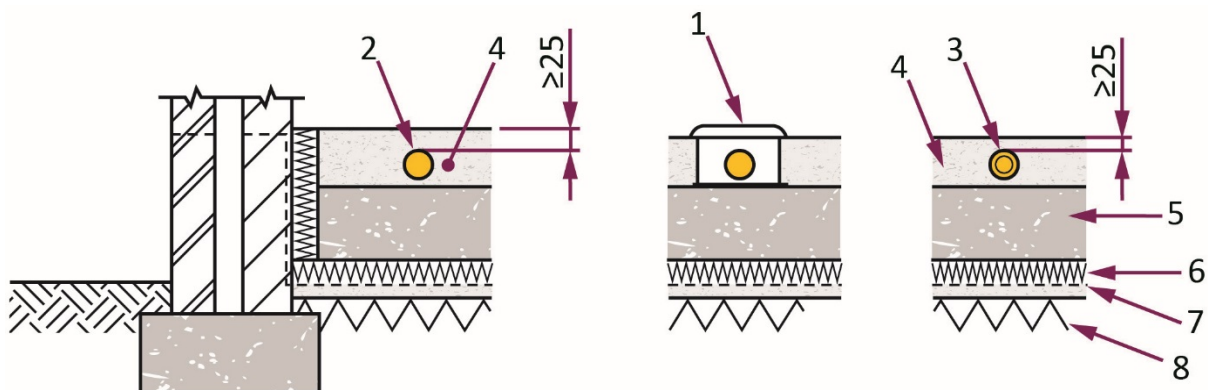

Key to Figure 4a

| | | | |
|---|--|---|----------------------------|
| 1 | TracPipe® / TracPipeCC® laid in preformed duct | 5 | Concrete Slab |
| 2 | TracPipe® / TracPipeCC® directly buried in non-structural screed or topping | 6 | Insulation |
| 3 | TracPipe® directly buried in non-structural screed or topping with optional additional soft sleeving | 7 | Damp-proof membrane |
| 4 | Non-structural screed or topping | 8 | Hardcore and sand blinding |

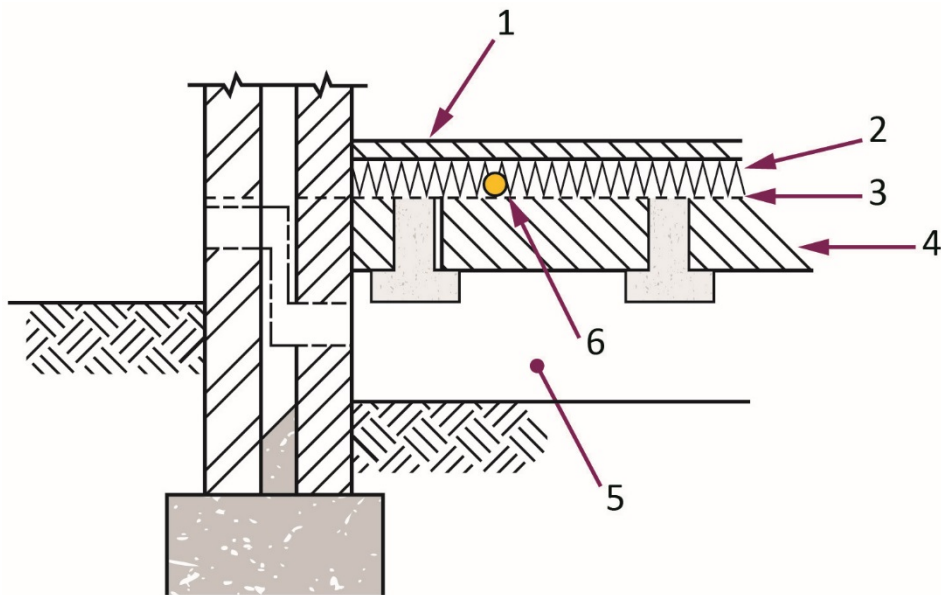
Figure 4b Typical examples of internally buried pipework (Suspended Concrete Floors)

Key to Figure 4b

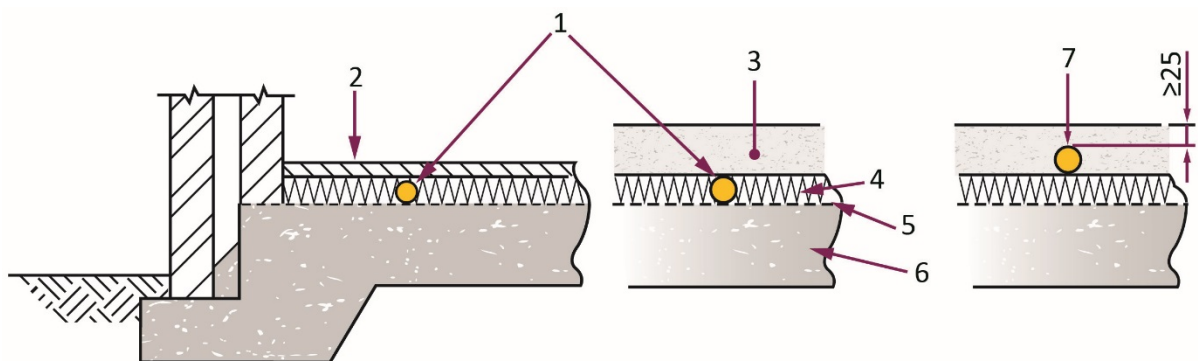
- | | | | |
|---|---|---|------------------------------|
| 1 | Chipboard or floor screed over insulation | 4 | Precast beam and block floor |
| 2 | Insulation | 5 | Ventilated void |
| 3 | Damp-proof membrane | 6 | TracPipe® / TracPipeCC® |

Figure 4c Typical examples of internally buried pipework (Concrete Raft)

Key to Figure 4c

- | | | | |
|---|--|---|---|
| 1 | TracPipe® / TracPipeCC® laid in insulation layer | 5 | Damp-proof membrane |
| 2 | Chipboard over insulation | 6 | Concrete raft |
| 3 | Screed over insulation | 7 | TracPipe® / TracPipeCC® in non-structural screed or topping |
| 4 | Insulation | | |

8.6.3 Cavity walls

TracPipe® and TracPipeCC® shall not be placed within the structural cavities of cavity walls. Every pipe passing through a cavity wall shall take the shortest practicable route and shall be sleeved (see Clause 8.7).

8.6.4 Dry lined walls

TracPipe® and TracPipeCC® installed behind dry lining shall be encased by building material. For typical examples see Figures 5b and 5c. Examine the entire run of the pipework visually and manually to check for any damage or voids in the yellow polyethylene cover. Repair any damage as described in Clause 8.5.2 with TracPipe® self-amalgamating silicone tape.

8.6.5 Timber-frame and light steel-framed walls

Important – the requirements for gas installation pipework within timber-frame and light steel-framed walls is produced in detail in BS 6891: 2015 and IGE/UP/7 Current Edition and should be referred to before installing TracPipe® in this type of construction. The information below covers key aspects of installing TracPipe® and TracPipeCC® within this construction but must not be considered exhaustive.

TracPipe® and TracPipeCC® passing from one side of timber-frame and light steel-framed construction to other side must take the shortest practical route and be sleeved (see Clause 8.7).

TracPipe® and TracPipeCC® installed within the walls of timber-frame and light steel-framed construction must be run within purpose-designed channels (see Figures 6a and 6b) or ducts;

TracPipe® and TracPipeCC® must be installed such that any fixing cannot penetrate it, for example plasterboard fixings, screws or shot-fired nails which are typically up to 50mm long. This can be achieved by ensuring that the pipework is installed more than 50mm from the decorative surface of the plasterboard.

If this cannot be achieved, where the pipework is run within 50mm of the decorative face of the plasterboard, it must be protected suitably against penetration, for example with a steel plate of minimum thickness 1mm (see Figures 6a and 6b).

Where a gas supply point is to be positioned on a separating or compartment (party) wall, the pipework needs to rise in front of the finished plasterboard face.

Provision needs to be made for pipework to accommodate any normal differential movement or shrinkage of timber construction walls, with particular attention given to multi-storey buildings.

A suitable method of accommodating movement for TracPipe® and TracPipeCC® passing through a masonry outer wall and timber-frame inner wall is shown in Figure 7.

Figure 5a Typical example of TracPipe® or TracPipeCC® installed in masonry construction wall (Brick and Block Plastered)

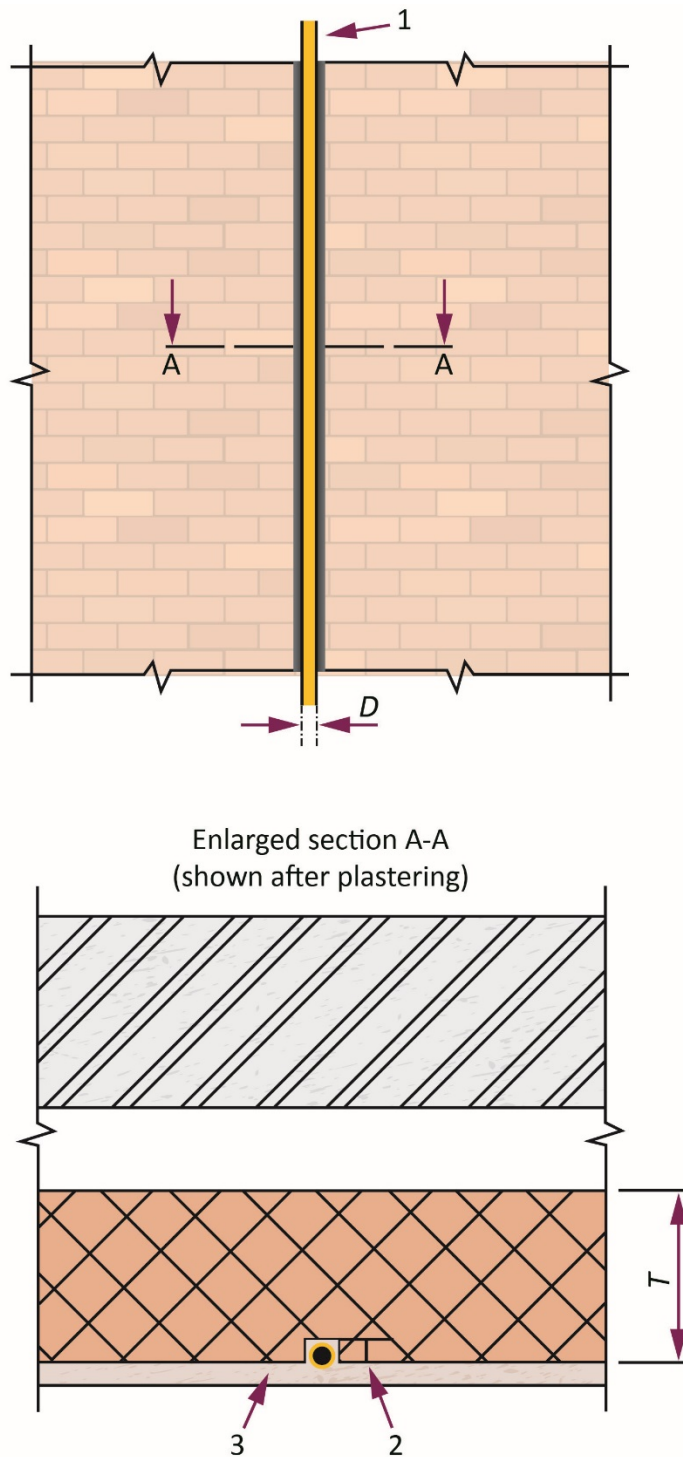

Key to Figure 5a

- | | | | |
|---|--------------------------------------|---|--|
| 1 | TracPipe® / TracPipeCC® set in chase | 3 | Pipework set into chase in plastered wall |
| 2 | Depth of chase | D | Maximum depth of chase: $T/6$ horizontal; $T/3$ vertical |

Figure 5b Typical example of TracPipe® or TracPipeCC® installed in masonry construction wall (Brick and Block with dry lining on dabs)

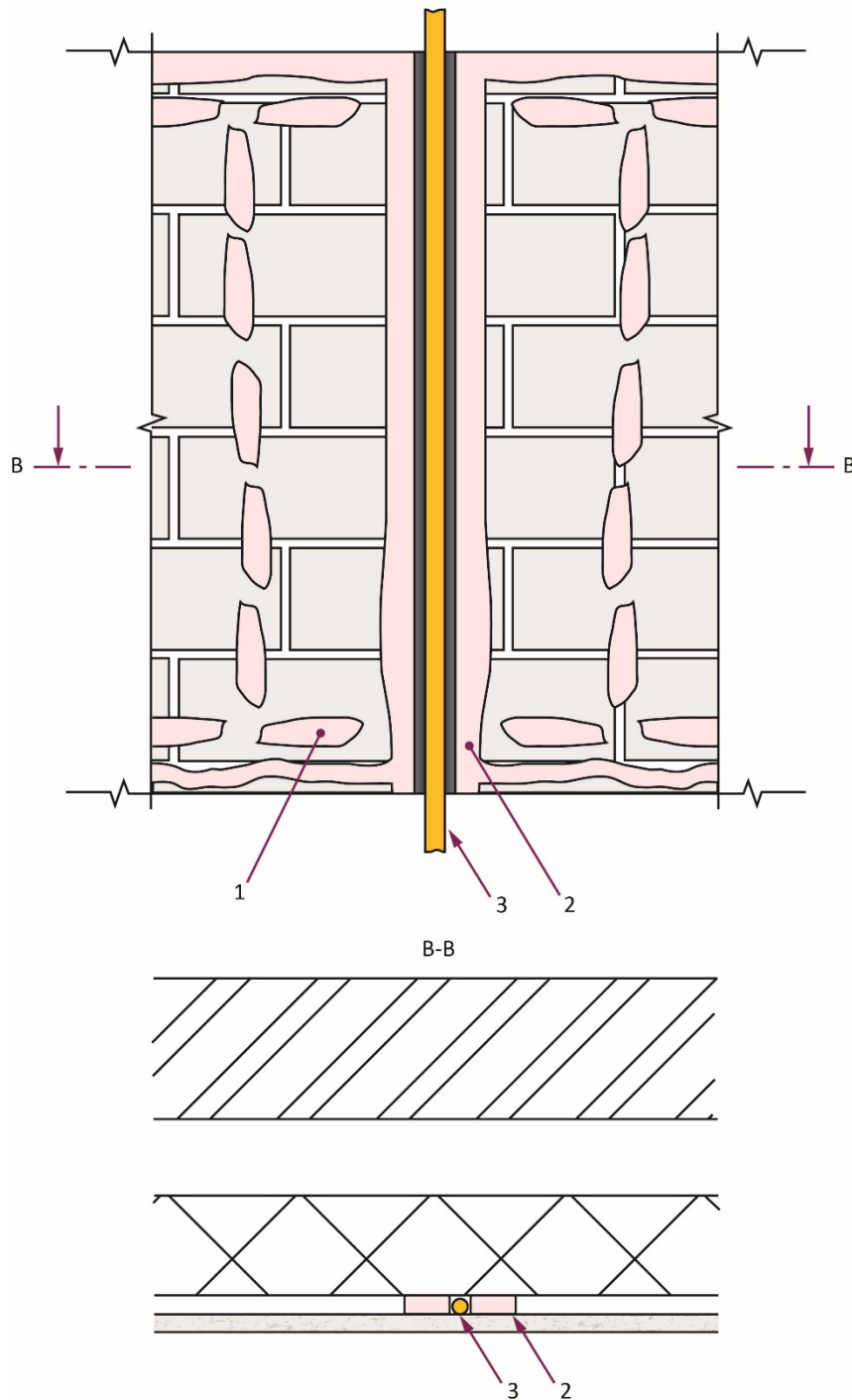

Key to Figure 5b

- 1 Individual adhesive dabs
- 2 Continuous adhesive dabs surround TracPipe®
- 3 TracPipe® / TracPipeCC®

Figure 5c Typical example of TracPipe® or TracPipeCC® installed in masonry construction wall (Brick and Block with dry lining on wooden battens)

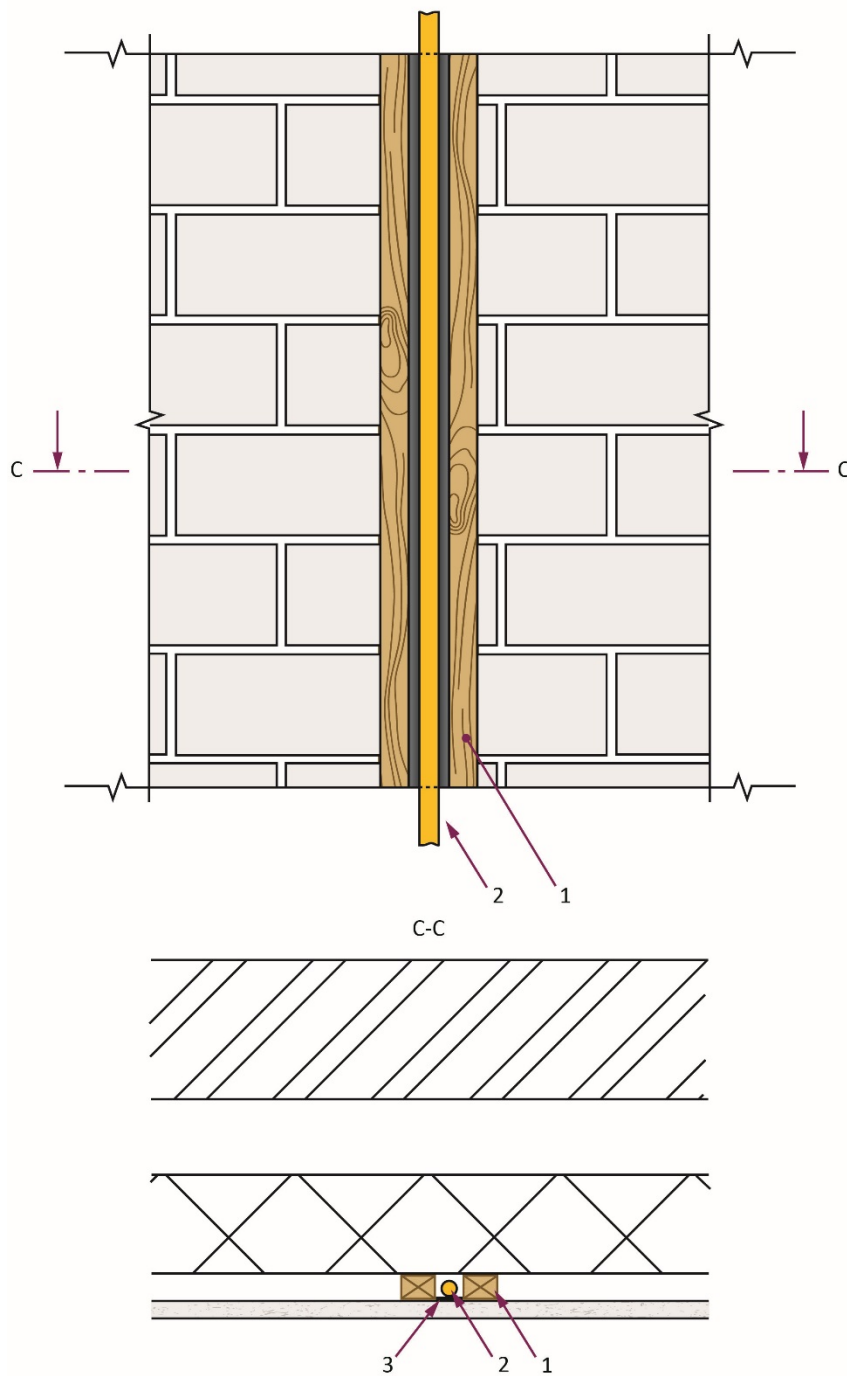

Note: Joints between the wall and the studs must be sealed with a suitable mastic to avoid escaping gas tracking around the wooden studs.

Key to Figure 5c

- 1 Timber battens
- 2 TracPipe® / TracPipeCC®
- 3 Steel plate of a minimum 1mm thickness

Figure 6a Typical example of TracPipe® or TracPipeCC® installed in timber and light steel-framed construction walls (TracPipe® / TracPipeCC® passing through timber-frame wall)

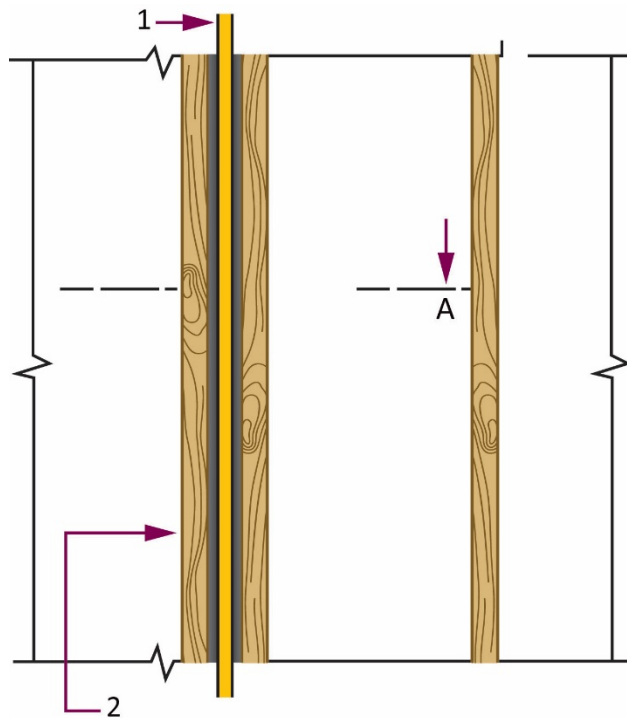

**Enlarged section A-A
(shown with plasterboard in place)**

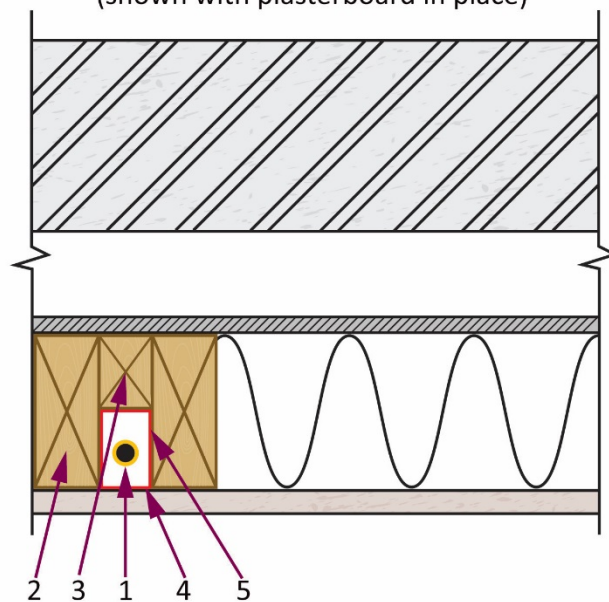

Note: Joints between the wall and the studs must be sealed with a suitable mastic to avoid escaping gas tracking around the wooden studs.

Key to Figure 6a

- | | | | |
|---|----------------------------|---|------------------------------------|
| 1 | TracPipe® / TracPipeCC® | 4 | Steel plate (min. 1mm thickness) |
| 2 | Timber stud | 5 | Joints sealed with suitable mastic |
| 3 | Timber stud blocking piece | | |

Figure 6b Typical example of TracPipe® or TracPipeCC® installed in timber and light steel-framed construction walls (TracPipe® / TracPipeCC® installed in a timber-framed wall)

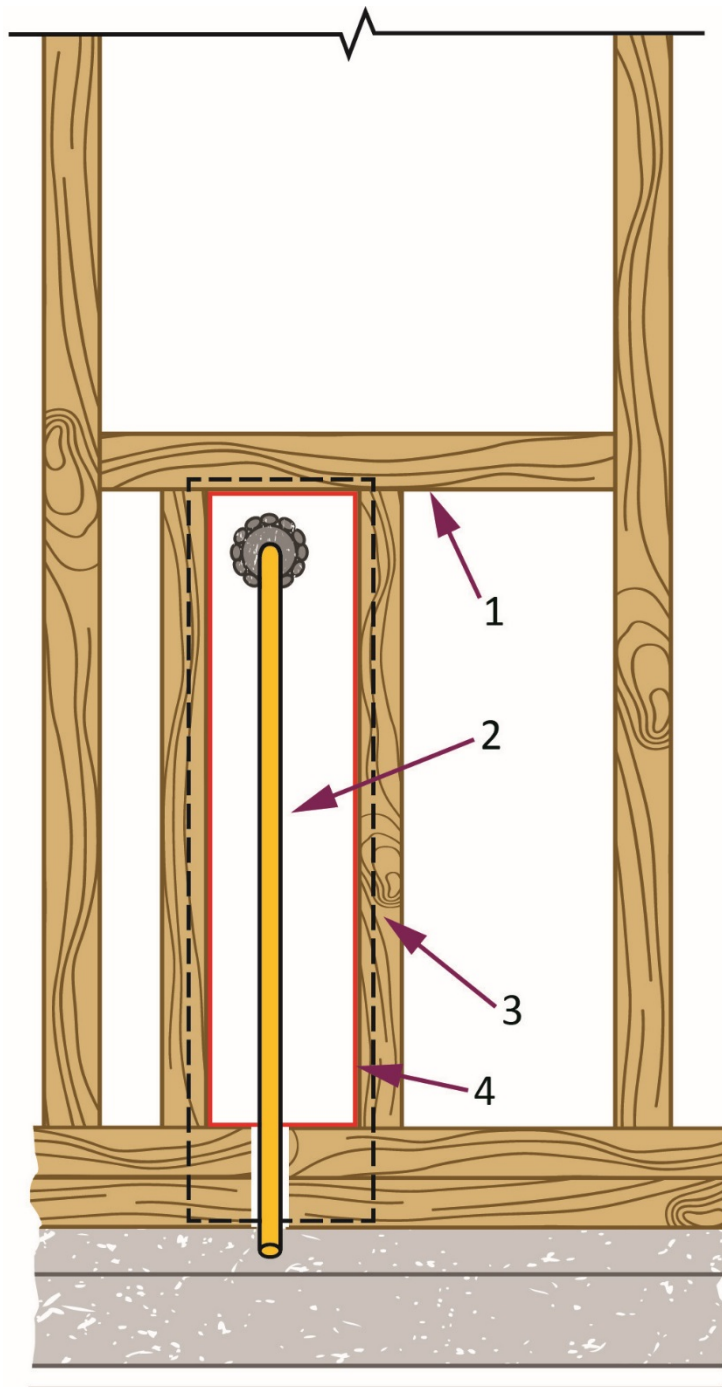

Note: Joints between the wall and the studs must be sealed with a suitable mastic to avoid escaping gas tracking around the wooden studs.

Key to Figure 6b

- 1 Timber stud
- 2 TracPipe® / TracPipeCC®
- 3 Steel plate of a minimum 1mm thickness
- 4 Joints sealed with suitable mastic

Figure 7 Typical method of accommodating movement for pipework passing through a masonry/timber-frame wall

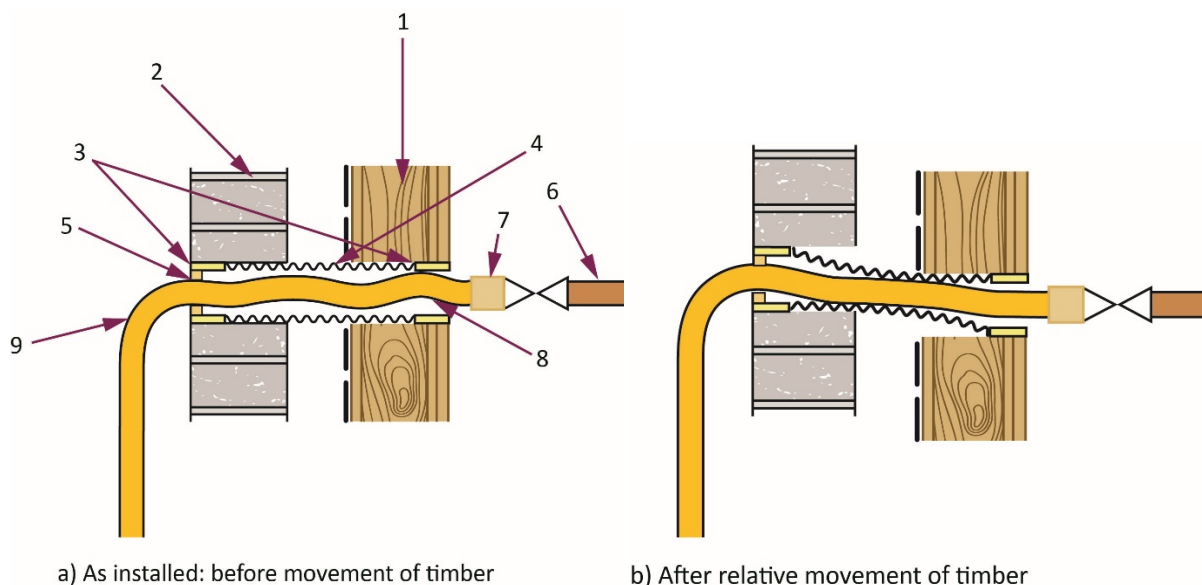

Key to Figure 7

- 1 Timber frame
- 2 Masonry external wall or wall of internal riser
- 3 Sealant between sleeve and wall
- 4 Flexible pipe sleeving
- 5 Flexible sealant between TracPipe® / TracPipeCC® and sleeve, on one end of the sleeve only (preferably external side to prevent water ingress)
- 6 TracPipe® / TracPipeCC® or rigid pipe
- 7 AutoFlare® fitting
- 8 TracPipe® / TracPipeCC®
- 9 Bend radius not to exceed maximum stated in Table 2

8.6.6 Solid walls

Every pipe, including TracPipe® and TracPipeCC®, passing through a wall shall be sleeved.

8.7 Sleeves

8.7.1 Where TracPipe® and TracPipeCC® passes through a wall or a floor, whether or not it contains a cavity, it shall pass through a suitable sleeve.

Sleeves shall be resistant to corrosion and be of a material impermeable to gas, e.g. copper, steel, polyethylene, or other suitable plastic material.

Note: Care should be taken to ensure that PVC does not come into contact with stainless steel owing to the risk of corrosion.

No sleeve shall have joints along its length.

The sleeve shall be capable of protecting the pipework against failure caused by movement of the structure.

- 8.7.2 Sleeves shall pass through the full width of the wall or the full thickness of the floor. Sleeves shall not impair the structural stability, fire resistance, thermal and sound insulation of a building.

The internal diameter of any sleeve should allow for an annular space around the pipe to enable satisfactory insertion of the pipe into it and be of sufficient diameter to allow adequate sealing between the pipe and the sleeve.

The sleeve should be sealed at one end only with a flexible fire resistant compound, the other end being ventilated, preferably to open air. In the case of a sleeve within a gas meter box, this will not be possible, as the sleeve should be sealed at the point of entry into the building to prevent an accumulation of gas entering the building.

- 8.7.3 Sleeves shall be sealed at each end to the structure of the building with a suitable building material, e.g. cement mortar or flexible sealant.

- 8.7.4 AutoFlare® fittings shall not be located within the sleeve.

8.8 Pipework in ducts

8.8.1 General

Wherever possible, vertical and horizontal ducts containing TracPipe® should be ventilated to ensure that minor gas leakage does not cause the atmosphere within the duct to become unsafe. However it is accepted that in modern building design, particularly with multi dwelling buildings, there may be short sections of unventilated voids where it is necessary to route gas installation pipework.

Where TracPipe® needs to pass through an unventilated void it can be routed within a secondary containment (see Annex E).

TracPipeCC®, by nature of its unique patented design, is manufactured with the secondary containment in place and therefore does not need to be additionally sleeved (other than through walls/floors) – see Clause 8.8.3.

Note: Fire-separation may need to be considered, dependant on the location of the void.

8.8.2 Ventilation

Vertical ducts may run freely through a number of storeys or take the form of an enclosure at each storey level. Where ducts are continuous, ventilation can normally be achieved by the provision of openings sized in accordance with Table 3 (see Figure 8a). Where the duct takes the form of an enclosure at each storey level, air vents can either communicate direct to outside air or communicate with an area that is naturally ventilated in accordance with the Building Regulations (see Figure 8b). Any ventilation opening must be located such that air movement can occur within the duct.

Figure 8a Typical installation pipework in multi-storey buildings containing flats or maisonettes (Ventilated Duct)

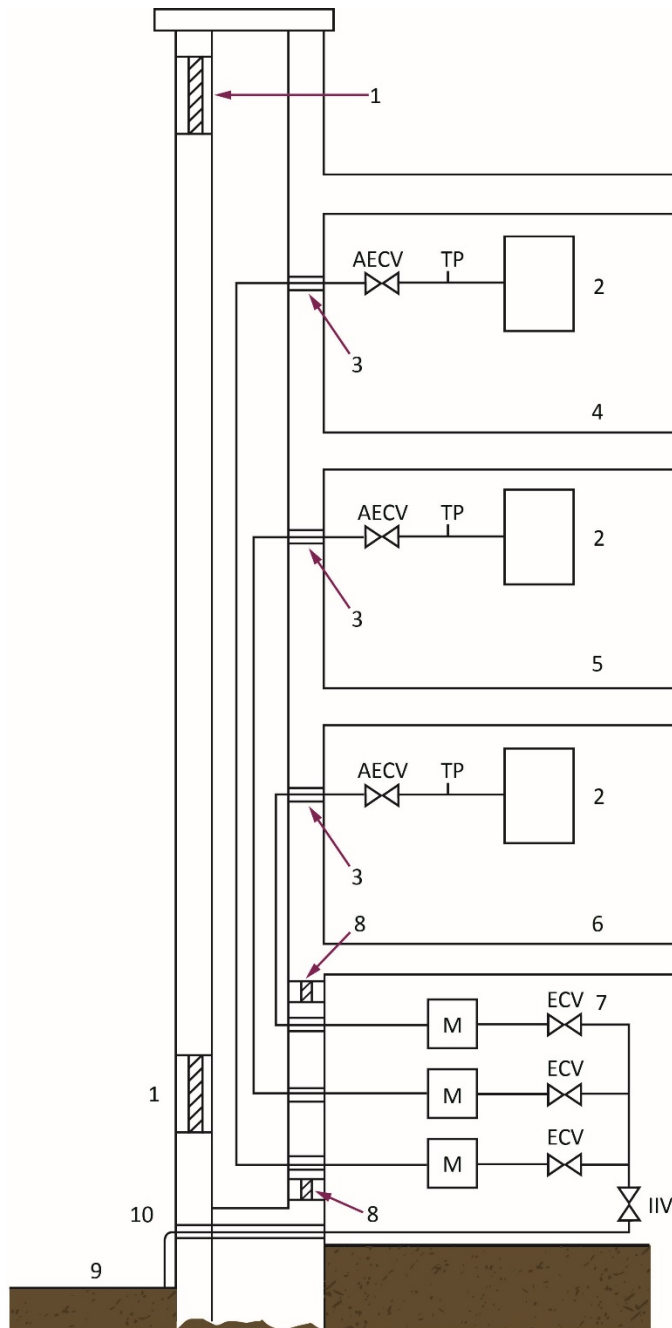

Key to Figure 8a

| | | | | | |
|---|-------------|----|------------------------|------|------------------------------------|
| 1 | Ventilation | 6 | Flat 1 | ECV | Emergency Control Valve |
| 2 | Appliance | 7 | Meter room | AECV | Additional Emergency Control Valve |
| 3 | Fire stop | 8 | Meter room ventilation | IIV | Inlet isolation valve |
| 4 | Flat 3 | 9 | Ground level | M | Gas meter |
| 5 | Flat 2 | 10 | Gas service | TP | Test point |

Figure 8b Typical installation pipework in multi-storey buildings containing flats or maisonettes – Fire stopped pipework and ventilated enclosed area

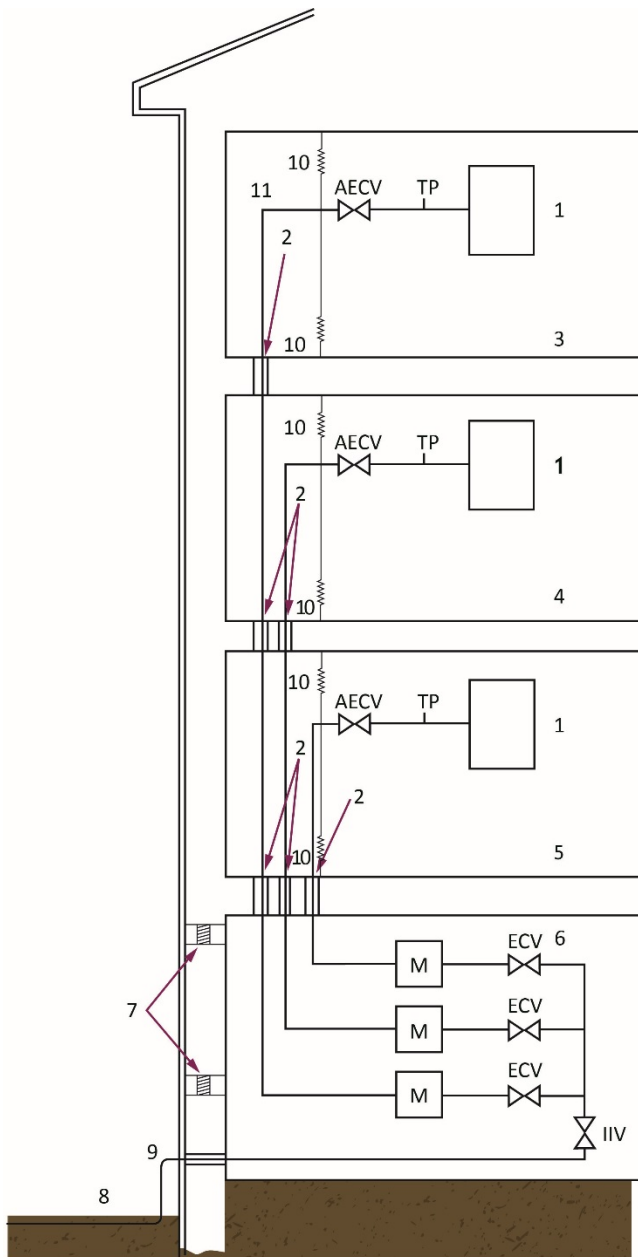

Key to Figure 8b

| | | | | | |
|---|------------|----|------------------------|------|------------------------------------|
| 1 | Appliance | 7 | Meter room ventilation | ECV | Emergency Control Valve |
| 2 | Fire stop | 8 | Ground level | AECV | Additional Emergency Control Valve |
| 3 | Flat 3 | 9 | Gas service | IIV | Inlet isolation valve |
| 4 | Flat 2 | 10 | Vent | M | Gas meter |
| 5 | Flat 1 | 11 | Enclosure | TP | Test point |
| 6 | Meter room | | | | |

Note: Ventilation grilles need to communicate to an area that is ventilated to the relevant Building Regulations.

Table 3. Free area of ventilation openings

| Cross sectional area of duct (m ²) | Minimum free area of each opening (m ²) |
|--|---|
| Not Exceeding 0.01 | 0 |
| 0.01 and not exceeding 0.05 | Cross sectional area of duct |
| 0.05 and not exceeding 7.5 | 0.05 |
| Exceeding 7.5 | 1/150 of the cross sectional area of duct |

Ducts having a small cross sectional area and volume (i.e. 0.01m² or less with a total volume of less than 0.1m³) are considered to be adequately ventilated by adventitious means and no additional openings are required.

Note: Additional information is given in BS 8313.

Minor gas leakage is that which would remain undetected by normal tightness testing techniques. The level of ventilation is not intended to clear a major gas escape arising from damage or failure of a gas pipe.

8.8.3 Use of TracPipeCC® through unventilated voids

Important: Users of TracPipeCC® semi-rigid gas piping must liaise with those responsible for the Building Control and where appropriate the Home Warranty provider to ascertain their preferred method of installation.

When using TracPipeCC® through unventilated voids, it is important the secondary outer cover is not damaged during the installation. The secondary outer cover is forming the secondary containment required by BS 8313: 1997 *Code of practice for Accommodation of building services in ducts* for when conveying a flammable gas through an unventilated void, such as a horizontal ceiling void or vertical service riser. Practical points to note include;

1. Where TracPipeCC® passes through walls or floors it must still be sleeved in accordance with the requirements of Clause 8.7. At the meter box, TracPipeCC® should still pass through the sleeve/spigot provided, with the annular space being sealed within the meter box.
2. The entire length of TracPipeCC® needs to remain visible during installation so the outer cover can be visually inspected for any damage and repaired as required. Once it has been confirmed the outer cover is intact (or repaired as per 3 below), then it is acceptable to enclose the pipework fully.
3. In case of damage to the TracPipeCC® outer cover that would affect its properties as a sleeve (e.g. the secondary outer cover is fully penetrated), repair any damage to the cover using TracPipe® self-amalgamating silicone tape applied with a 55% overlap to a minimum of 50mm either side of the damage. See Section 11 for additional details. TracPipe® tape part numbers FGP-915-10H-12 (25mm wide) or FGP-915-20H12PO, (50mm wide).
4. TracPipeCC® must not be joined or teed in any unventilated space, unless the cross sectional area and volume of the space meet the requirements for nil ventilation as stated in Clause 8.8, Table 3 and the fittings themselves remain accessible.
5. Only continuous lengths (no joints) of TracPipeCC® can be routed within a protected shaft containing a stair and/or lift or other protected fire escape route (see Clause 8).

When the installation has been completed, it is recommended that a permanent record be made (such as on any commissioning paperwork) that the TracPipeCC® installation has been carried out in accordance the current TracPipe® and TracPipeCC® Design and Installation Specification. This will ensure those inspecting the installation at a later date are

aware that the void through which the TracPipeCC® is passing does not need to be additionally ventilated.

8.8.4 Fire resistance

The fire-resistance of any duct containing pipework shall have equal or greater fire rating as any void through which it passes or be correctly fire stopped where it passes through compartment walls or floors.

Note: Reference will need to be made to the appropriate Building Regulations for further guidance.

8.9 Multi-occupancy buildings

Where pipework passes through an individual dwelling/commercial unit other than the one it supplies, it must be located in a purpose-provided duct designed and constructed to prevent damage to the pipework (see Figure 8b).

Note: The Building Regulations may also contain provisions for the design and construction of such ducts.

8.10 Fire stopping

8.10.1 For buildings containing flats and maisonettes, installation pipes need to be fire stopped as they pass from one floor to another unless in their own protected shaft which is ventilated top and bottom to outside atmosphere. When installation pipes from a continuous duct enter a flat or maisonette they need to be fire stopped at the point of entry (see Figure 8a).

When pipes pass through the protecting structure (i.e. compartment walls or floors), all openings should be kept as small and as few in number as practicable. Pipes should be suitably fire stopped in such a manner as to allow thermal movement of the pipe and ensure the fire resistance is not impaired.

To prevent displacement, materials used for fire stopping should be supported by, or reinforced with, materials of limited combustibility.

Any proprietary fire stopping should, when tested in accordance with the appropriate part of BS 476, achieve the relevant periods of fire resistance for the structure in respect of load bearing capacity, integrity and insulation.

8.11 Gas pipework inside a protected shaft containing a stair and/or lift or other protected fire escape route.

8.11.1 In addition to the requirements for fire resistance (see 8.8.3) and fire stopping (see 8.10) any pipe carrying gas installed in, or passing through, a protected area shall be:

- a) steel pipework with screwed joints;
- b) steel pipework with welded joints;
- c) continuous length of copper (no joints);
- d) continuous length of pliable corrugated (stainless steel) tubing manufactured to withstand Fire Test A of BS EN 1775:2007, Annex A.

Note: BS 6891: 2015 states that pliable corrugated (stainless steel) tubing manufactured to BS 7838 meets Fire Test A. For pliable corrugated tubing manufactured to BS EN 15266 the manufacturer should be consulted.

TracPipe® and TracPipeCC® meet the requirements of the recently withdrawn BS 7838 and Fire Test A of BS EN 1775:2007, Annex A and can therefore be installed in a protected shaft but it must be a continuous length (without joints).

- 8.11.2 Other than the exceptions as described in 8.11.3, a protected area containing gas pipework needs to be ventilated at high and low levels direct to the outside air. Sizes of ventilation openings must be in accordance with Table 3. It is not permissible to use mechanical ventilation to achieve the required ventilation levels of the protected area.

Note: A pipe is not considered to be within a protected area if the pipework is completely separated from that protected area by fire-resisting duct that is itself ventilated direct to outside air (see Table 3).

The fire/acoustic performance of a suspended ceiling or the fire performance of any area or structure (such as a riser) should be confirmed with the building designer or the local building control body.

Further guidance on protected areas is given in the appropriate Building Regulations and other applicable building standards.

The requirements given in 8.11 does not normally apply to one or two storey domestic dwellings.

8.11.3 Gas pipework in a protected corridor/lobby

- 8.11.3.1 For continuous lengths of TracPipe® or TracPipeCC® within a protected corridor/lobby (see Annex C – Definitions), including any suspended ceiling void above the protected area, gas pipework can be contained within a duct which is vented to outside air either directly or indirectly via another ventilated area. The duct will need to be of fire-resisting construction to the level of the fire resistance of the protected area it passes through or of an alternative material with fire stopping where the duct passes through the compartment walls/floors.

- 8.11.3.2 As TracPipe® and TracPipeCC® in continuous lengths (without joints) are a continuously welded stainless steel gas pipe and meet the requirements of 8.11.1 d), they can be installed within a protected corridor/lobby which is not ventilated direct to outside air, provided the protected corridor/lobby is deemed “normally occupied” (see Annex C – Definitions). If the pipework is installed above a suspended ceiling, which does not form part of the required fire/acoustic performance of the compartment floor, the ceiling void can be vented into the normally occupied protected corridor/lobby via vents inserted through the ceiling. These vents shall be sized and installed in accordance with Table 3.

- 8.11.4 If the gas pipework is within a duct and any inspection hatch or door opens from that duct into a protected area, that hatch or door needs to be of at least the same fire resisting construction as the protected area in which it is fitted. The hatch or door must also be suitably sealed on all edges to contain any gas escape within the duct.

Note: *The seals to be used should enable the hatch or door to be opened without comprising the integrity of the seal when the hatch or door is closed.*

8.12 Pipe Support

- 8.12.1 The outside diameter of TracPipe® and TracPipeCC® are larger than that of similar sized rigid steel or copper pipe. Therefore for TracPipe®, the clip/support size required is generally considered as the next size up in the clipping range (e.g. For DN15 TracPipe® use clips suitable for 22mm). The type of clip will depend on the installation but in most cases either a metal (Munsen) or plastic clip with a securing device will be used. TracPipeCC® outside diameters are slightly larger again due to the additional secondary cover so methods of support that offer a range of size (such as Munsen style clips) would be beneficial.

Note: *Outside Diameters (OD) of TracPipe® and TracPipeCC® can be found in Section 12 - TracPipe® and TracPipeCC® System Components.*

It is also possible to install all sizes of TracPipe® and TracPipeCC® upon cable tray/basket that are suitably secured to the building fabric. In this case the TracPipe® or TracPipeCC® will be continually supported throughout its length. Where TracPipe® or TracPipeCC® is laid upon cable tray/basket, it is important that the pipework is secured to the cable tray (e.g. with cable ties). Where the pipework is fixed below the cable tray/basket (or the cable tray/basket is routed vertically) then the pipework will need to be secured in place with appropriate cable ties suitable for the environment in which they are used.

All pipework supports shall be suitable for the environment in which they are installed and shall be designed to remain stable for the lifetime of the installation, e.g. for external use corrosion resistant or UV-stabilized plastic.

- 8.12.2 Where the TracPipe® or TracPipeCC® is passing through a fire protected area, all support clips and ties must be of a suitably rated fire resisting material.

If TracPipe® or TracPipeCC® is being secured to the underside of cable tray/basket and is passing through a fire protected area, the method of securing the pipework to the tray/basket should be of fire resisting material (e.g. fire rated metallic cable ties).

TracPipe® and TracPipeCC® shall be supported at the maximum intervals outlined in Table 4.

Table 4: Maximum support intervals for TracPipe® and TracPipeCC®

| Nominal size | Interval for vertical run (m) | Interval for horizontal run (m) |
|---------------------|-------------------------------|---------------------------------|
| ≤ DN15 | 2.0 | 1.5 |
| DN22, DN28 and DN32 | 2.5 | 2.0 |
| DN40 and DN50 | 2.5 | 2.0 |

8.13 Exterior pipework

- 8.13.1 TracPipe® and TracPipeCC® are suitable for exterior, exposed use. The yellow polyethylene cover has been tested for ultraviolet and ozone attack as well as colour fade. The cover should be checked for damage, and repaired if necessary as outlined in Clause 8.5.2. Unlike rigid pipe, further painting and labelling is not necessary. Any exposed stainless steel should be covered with TracPipe® self-amalgamating silicone tape, (see 7.1.6).

8.14 Buried pipework

8.14.1 Internal environment

8.14.1.1 TracPipe® or TracPipeCC® that is buried in a solid floor (including magnesium-oxy-chloride cement or magnesite flooring) or wall must be installed in accordance with Clause 8.5.1.

The outer cover of the TracPipe® or TracPipeCC® shall be examined for cuts or other defects and made good prior to use. Any portions of exposed stainless steel or cut cover shall be wrapped with self-amalgamating silicone tape TracPipe® P/N FGP-915-10H-12, (25mm wide), or FGP-915-20H12PO, (50mm wide). This will reduce the possibility of later external corrosive attack.

Protective measures are applied as a precaution against electrolytic and/or chemical corrosion.

8.14.2 External environment

8.14.2.1 When routing pipework, consideration shall be given to the soil type in which it is to be laid and its likely corrosion impact over time.

8.14.2.2 Buried metallic pipework (other than proprietary systems intended for underground use) can only be installed when appropriate and where:

- a) a risk assessment has been carried out; and
- b) an inspection strategy has been developed and provided to the gas consumer.

TracPipe® and TracPipeCC® are suitable for external applications, including burial. The integrity of the polyethylene cover should be checked and rectified if necessary (see 8.5.2). AutoFlare® fittings must not be buried.

8.14.2.3 Where pliable corrugated (stainless steel) tube is to be buried externally, it shall be:

- a) directly buried pliable corrugated (stainless steel) tube which:
 - 1) the manufacturer's instructions specifically allow direct burial;
 - 2) is installed in accordance with the manufacturer's instructions; and
 - 3) has a factory-applied cover with a minimum thickness of 0.5mm, manufactured from a non-chlorinated material of a synthetic polymer or elastomer with a total chloride content not exceeding 50ppm; or
- b) laid inside a buried outer pipe conforming to 8.7 *Sleeves* or a covered channel which terminates either above ground or in a suitable inspection pit, such as to prevent the accumulation of water in the outer pipe or duct, while still enabling periodic inspection.

TracPipe® (Kitemarked to BS EN 15266) is manufactured to the requirements of the recently withdrawn BS 7838 and therefore meets the requirements for direct burial including the minimum thickness of outer cover and the maximum allowable chloride content. TracPipeCC® is also suitable for direct burial as the secondary cover provides additional protection and is above that required by the installation standard. Products manufactured to BS EN 15266 only may not meet the above requirements for minimum thickness of cover and maximum chloride content as they do not form part of the BS EN 15266 manufacturing requirements.

8.14.2.4 When burying TracPipe® or TracPipeCC® externally, Table 5 (domestic/light commercial) or Table 6 (industrial/commercial) should be applied depending on the type of installation being undertaken.

Table 5: Buried external Pipework – minimum depth of cover requirements (BS 6891)

| Location of pipework | Minimum depth of cover (mm) |
|--|-----------------------------|
| Private gardens including pathways (no vehicular traffic) | 375 |
| Private drives with light vehicular traffic | 450* |
| Private drives where there is a likelihood of heavy traffic (such as LPG road tankers) | 600* |
| Fields and agricultural land | 1100* |
| Other private ground | 600* |

**Where, due to ground conditions, it is not possible to excavate a trench to give the specified depth of cover, additional mechanical protection shall be provided above the pipe such as burying concrete slabs below ground level at approximately 100mm above the pipework*

Table 6: Buried external Pipework – minimum depth of cover requirements (IGEM/UP/2)

| Location of pipework | MOP less than or equal to 75mbar (mm) | Greater than 75mbar up to 2bar (mm) |
|------------------------------------|---------------------------------------|-------------------------------------|
| Carriageways | 450 | 750 |
| Path footways | 375 | 600 |
| Verges | 600 | 750 |
| Other fields and agricultural land | 1100 | 1100 |
| Other private ground | 600 | 600 |
| Water courses, rivers and canals* | 600 | 1200 |
| Railways** | 1.4 | 1.4 |

**Reference to be made to the appropriate environmental agency for permission to cross these features*
***Refer to the appropriate authority*

8.14.2.5 UKLPG COP22 requires that LPG service pipework operating at less than 500mbar be buried with a minimum depth of cover of 350mm where there is negligible risk of interference/mechanical damage or at 600mm where there is a greater risk of damage. This

dimension can however be reduced if the service pipework is protected against possible damage e.g. by laying concrete slabs approximately 100mm above the service pipework.

UKLPG COP 22 states for LPG installations, buried metallic pipework (other than proprietary systems intended for underground use) should only be used when an appropriate:

- Risk Assessment has been carried out;
- Inspection and Maintenance Strategy has been developed and implemented

Where this is proven acceptable then TracPipe® or TracPipeCC® should be installed in either:

- a) a trench backfilled with inert, non-corrosive material free of abrasive material likely to damage its corrosion protection; or
- b) inside a buried outer pipe or covered channel which terminates either above ground or in a suitable inspection pit. The design should be such as to prevent the accumulation of water in the outer pipe or duct, while enabling periodic inspection.

8.14.2.6 Any trench should be excavated to firm ground at least 75mm (100mm if installing to IGEM/UP/2) below the required depth for the pipe to allow for the appropriate fine fill bedding. The pipework needs to be laid on cohesive or granular materials that are free from sharp stones rocks, bricks or concrete (see Figure 9).

Figure 9 Example of externally buried pipework (from BS 6891)

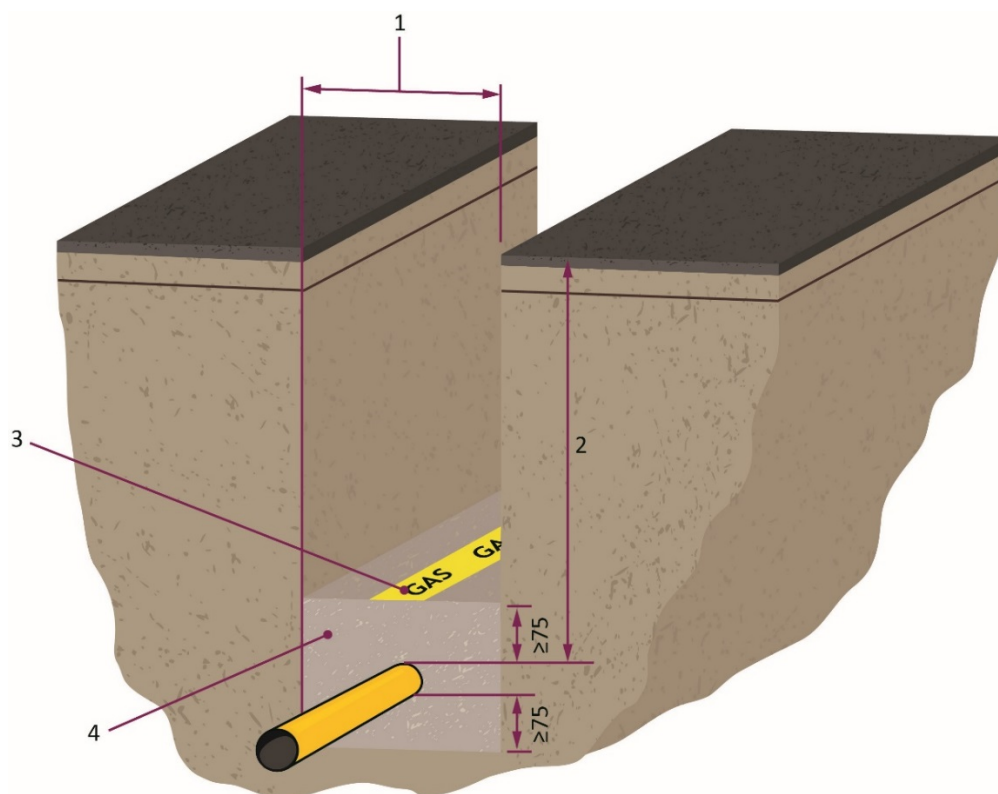

Key to Figure 9

- | | | | |
|---|------------------------|---|---|
| 1 | Minimum spade width | 3 | Gas marker tape (if required) |
| 2 | Minimum depth of cover | 4 | Cohesive or granular materials (e.g. sand or other fine material) |

8.14.2.7 For continuous lengths of TracPipe® and TracPipeCC®, the outer cover needs to be visually and manually checked for any damage. Where no damage of the outer cover has been identified the trench can be backfilled prior to tightness testing. If however during the inspection, damage to the outer cover has been identified, a successful tightness test of the TracPipe® or TracPipeCC® should be undertaken before the outer cover is repaired (see Section 11).

8.14.2.8 The backfill should be carried out progressively in layers from one end of the pipework installation and carefully consolidated to provide firm lateral support between the pipework and the trench.

The backfill at the sides and immediately above the pipework should be the same as that used for the bedding. A minimum of 75mm (100mm if installing to IGEM/UP/2) of cohesive or granular material must be backfilled above the pipework.

The use of wet clay should be avoided immediately adjacent to the pipework. Fill such as hard chalk must not be used as backfill material.

8.14.2.9 To facilitate future repair and maintenance, a minimum clearance of 250mm should where possible be maintained between pipework, foundations and the known position of other utilities (including electric cables, etc.), unless this is not reasonably practicable (e.g. crossovers).

Pipework shall not be installed under the foundations of a building or in the ground under the base of a wall or footings, unless adequate steps are taken to prevent damage to the pipework in the event of the movement of those structures or the ground.

8.14.3 In all cases, AutoFlare® fittings shall not be buried below ground or in screed.

8.15 Interrelation with other services

8.15.1 General

TracPipe® and TracPipeCC® must be located so that it does not touch metallic fittings, which can give rise to electrolytic corrosion.

The polyethylene cover should provide adequate protection where spacing is impracticable.

Care is essential when installing gas pipework in buildings containing electrical damp-proof protection systems to prevent accelerated pipe corrosion from occurring.

8.15.2 TracPipe® and TracPipeCC® must:

- a) not be installed in a ventilation plenum or air-conditioning duct; and
- b) be physically spaced from other services, such as water, electricity, telecommunication and drainage.

8.15.3 Separation from electrical services

Ideally TracPipe® and TracPipeCC® should be spaced:

- a) at least 150mm away from electricity supply equipment, such as metering equipment, main service cut outs or supplier (main) isolation switches and distribution boards or consumer units; and
- b) at least 25mm away from electrical switches, sockets and electricity supply and distribution cables.

Note: *The installation pipework shall not be positioned in a manner that prevents the operation of any electrical accessory, i.e. a switch or socket outlet.*

Where spacing requirements are impracticable the polyethylene cover of TracPipe® and TracPipeCC® will provide adequate protection.

8.15.4 Care shall be taken not to damage any electrical conductor when installing pipework.

TracPipe® and TracPipeCC® shall not be buried in floors where electrical underfloor heating is installed, unless it has been physically and permanently disconnected.

8.15.5 Main protective bonding conductor

8.15.5.1 All domestic gas installations shall have a main protective bonding conductor for the gas installation pipework conforming to BS 7671 (IEE Wiring Regulations).

The purpose of electrical bonding is to create a zone in which voltage differences, and therefore hazards from electric shocks, are minimized. This is achieved by connecting separate conductive components together with earthing cable or metal pipework.

It is possible for stray currents to be transmitted through the gas installation pipework. Therefore, to avoid electric shock, or a spark, which could ignite the gas, it is important to maintain electrical continuity in the pipework at all times.

8.15.5.2 The main protective bonding conductor shall be connected:

- a) as near as practicable to the point of entry in to the premises;
- b) before any branch in the installation pipework;
- c) in a position where it is accessible, can be visually observed, and fitted with a warning label stating 'Safety electrical connection. Do not remove';
- d) by a mechanically and electrically sound connection which is not subject to corrosion (i.e. not exposed to the weather).

8.15.5.3 The main protective bonding conductor (main equipotential bonding connection) shall not be directly connected to any pliable corrugated (stainless-steel) tube or pliable connectors from the outlet of the primary meter installation.

For TracPipe® and TracPipeCC® installations, the main protective bonding conductor should be connected to the AutoFlare® fitting and never on the pipework itself. The self-amalgamating tape should run fully over the back nut, leaving sufficient space to apply the earthing connection to the fitting body.

8.15.5.4 The main protective bonding conductor of the gas installation pipework should be a minimum of 10mm² cable with green and yellow insulation, construction reference 6491X conforming to BS 6004.

8.15.5.5 For internal meters, for verification purposes the bonding connection should be within 600mm of the meter outlet.

For meters in outside meter boxes/compartments, the bonding connection should be preferably inside the building and as near as practicable to the point of entry of the installation pipework into the building. Alternatively, the connection may be made within the meter box/compartment, but it is essential that the bonding cable does not interfere with the integrity of the meter box/compartment and the sealing of any sleeve.

8.15.5.6 When relocating a meter, an existing main protective bonding conductor may be satisfactory as found, or it may need to be altered. Where the bonding conductor requires altering any alterations should be carried out by an electrically competent person and inspected and

tested in accordance with BS 7671. The bond connection is satisfactory if the conditions of 8.15.5 are met.

- 8.15.5.7 When a gas installation pipe is connected to a primary meter installation, the installer of the installation pipe shall, in the case where main protective bonding conductor may be necessary, inform the responsible person that such bonding should be carried out by an electrically competent person.

For new gas installations the responsibility for the main protective bonding conductor lies with the installer to preferably carry out the bonding directly, where competent to do so. Alternatively, the installer should pass notification (e.g. a letter or card) to the responsible person (e.g. house owner, tenant, landlord or builder).

8.16 Valves

- 8.16.1 An emergency control valve (ECV) shall always be fitted.

The ECV is not part of the installation pipework system. It is usually installed at the end of the service pipe for natural gas and at the end of the service pipework for LPG. The ECV is not an “additional emergency control valve” (AECV), see 8.16.2.

- 8.16.2 An additional emergency control valve (AECV) is not an ECV (see 8.16.1). An AECV is intended to allow the consumer of gas to shut off the gas supply (typically within the premises) in an emergency, and is located downstream of the ECV. An AECV may not isolate all the installation pipework.

An additional emergency control valve (AECV) shall be fitted where the emergency control valve (ECV) is located remotely from the dwelling/building it serves (see Figure 10).

- 8.16.3 Every additional emergency control valve shall:

- a) be located as near as practicable to the point of entry of the installation pipework into the dwelling/building;
- b) be labelled or marked to show its open and closed positions;
- c) be fitted in an accessible position;
- d) be easy to operate;
- e) be fitted with a suitable handle, which is securely attached, or other permanent means of operation;
- f) where the lever moves in the vertical plane the move to the 'off' position shall be in a downward direction.

It is recommended that the AECV be located between 450mm and 1450mm above floor level.

There shall be a permanent notice attached to the valve indicating that the valve is an 'Emergency Control for customers' use', giving the telephone number of the Gas Emergency Service, and advising the consumer on actions to be taken in the event of a suspected escape of gas.

The notice should also indicate the parts of the installation isolated by that valve.

Figure 10 Locations of Additional Emergency Control Valves

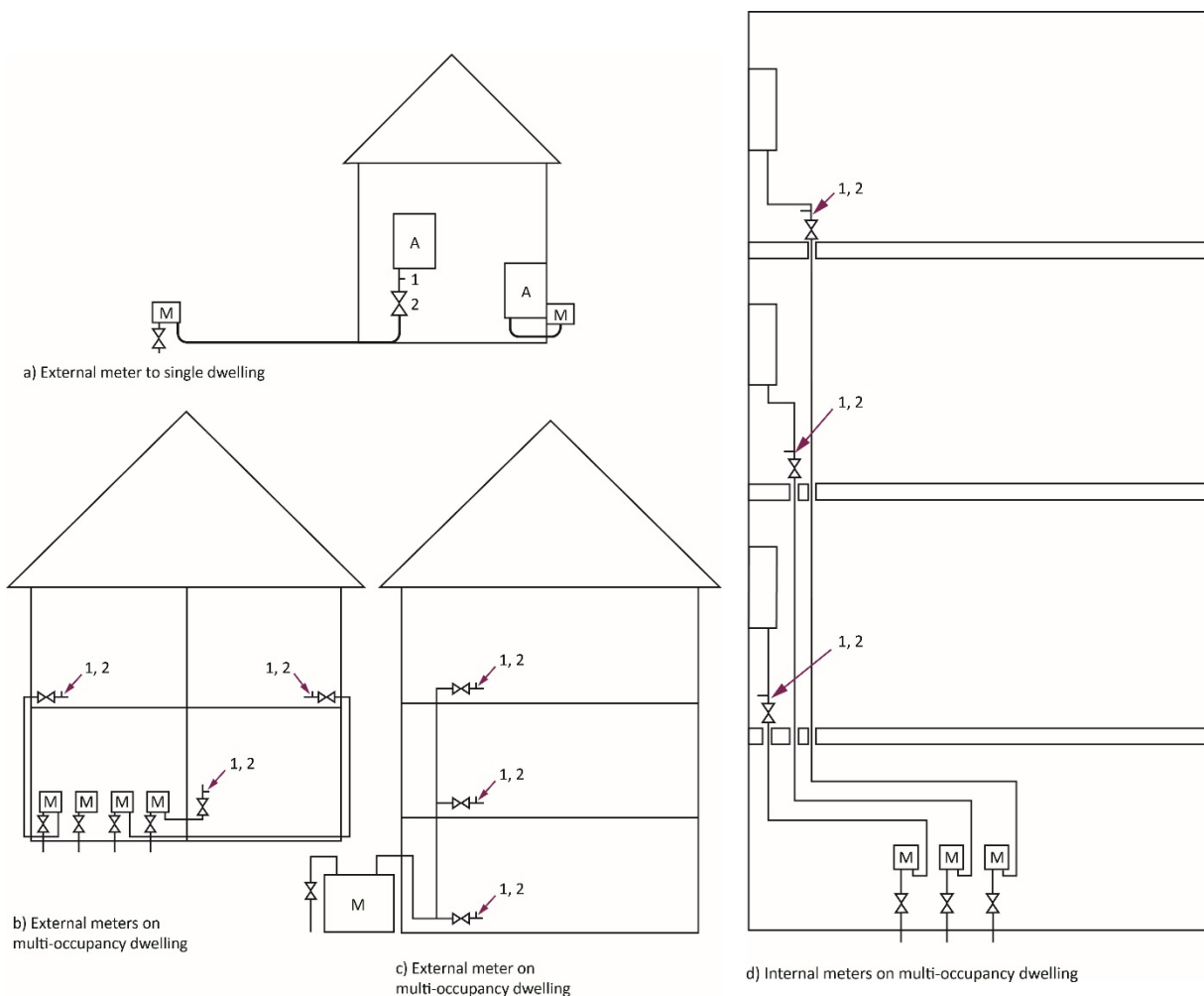

Key to Figure10

- | | | | |
|---|------------|---|-----------|
| 1 | Test point | A | Appliance |
| 2 | AECV | M | Meter |

8.16.5 A valve shall be fitted in an accessible position at the point of exit from a dwelling where the installation pipe leaves the dwelling to supply remote appliances. It is preferable that the valve be fitted externally in this case.

Appliances such as greenhouse heaters, barbecues and lighting are fitted external to the premises.

8.16.6 Pressure test points

8.16.6.1 A pressure test point for the purpose of tightness testing shall be installed no more than 300mm downstream of any ECV or AECV.

8.16.6.2 When an appliance is connected and a suitable means of confirming the pressure required by its instructions is not available, a test point needs to be fitted in the pipework at the point of connection.

Note: The ‘suitable means of confirming the pressure required’ may be incorporated in the appliance.

8.16.7 Purge points

8.16.7.1 Where it is not possible to purge through an appliance with an open burner, appropriately sized purge points need to be provided to enable the installation to be adequately purged (see IGEM/UP/1 series of standards).

8.16.7.2 Recommended purge point nominal bores are detailed in Table 7.

Table 7 – Recommended purge point nominal bores

| | | | | | |
|-------------------------------|----|----|----|----|----|
| Pipe nominal diameter (DN) | 20 | 28 | 32 | 40 | 50 |
| Purge point nominal bore (mm) | 20 | 20 | 20 | 20 | 25 |

9 - Corrosion

9.1 General

- 9.1.1 Pipework and fittings that are considered to be at risk of corrosion and degradation need to be either manufactured from materials that are inherently resistant to corrosion or should otherwise be suitably protected against corrosion.

Examples of pipework that is likely to be susceptible to corrosion and degradation are pipework buried in solid floors, pipework buried in walls, pipework routed externally above ground and buried external pipework.

Any factory-finished protection needs to be examined for cuts or other defects and made good prior to use. Any damage shall be repaired in accordance with the manufacturer's instructions to give at least the same level of protection that was afforded before the damage. Any onsite protection shall be applied to clean and dry pipework and fittings.

Some pre-insulation coatings, coverings, sheathings and wrapping tapes suffer from colour fade and surface cracking due to the effects of ozone or when exposed to direct sunlight or other ultra-violet (UV) sources. Therefore, care should be taken to ensure a suitable material is selected. Potentially corrosive environments also include pipework exposed pipework in coastal areas. Soot and debris in fireplace openings can be highly corrosive.

Where pliable corrugated (stainless-steel) tube fittings are used in an area considered to be at risk of corrosion and degradation, each fitting should be assembled in accordance with the manufacturer's instructions to ensure a liquid-proof seal is achieved between the factory-applied cover and the wall of the fitting.

TracPipe® and TracPipeCC® are supplied with a polyethylene cover with ultraviolet and ozone protection, which provides suitable corrosion resistance for a majority of installations. Care must be taken when assembling AutoFlare® fittings to assure that no stainless steel pipe is visible. Exposed stainless steel behind the fitting nut shall be wrapped with self-amalgamating silicone tape TracPipe® P/N FGP-915-10H-12, (25mm wide), or FGP-915-20H12PO, (50mm wide). This will reduce the possibility of later external corrosive attack.

9.1.2 Flux corrosion

It is important that TracPipe® and TracPipeCC® are not contaminated in any way with flux or solder, either internally or externally. Any soldering on adjacent copper pipework shall be completed, and the soldered component thoroughly cleaned of flux, before any connection to pipework is made.

9.1.3 Pipework in fireplace openings

Do not install TracPipe® or TracPipeCC® (including any AutoFlare® fitting) within the openings of all-fuel fireplaces. Soot and debris can be highly corrosive. TracPipe® or TracPipeCC® supplying this type of fireplace must be terminated outside of the firebox and the final connection made with suitably protected pipe. The flexibility of TracPipe® and TracPipeCC® can be utilised to carry out this type of installation.

- 9.1.4 Assembled pipework shall be tested for gas tightness in accordance with Section 10 before any additional protection against corrosion is applied on site.

10 - Testing for Gas Tightness, Purging and Confirmation of Adequacy of Pipework.

10.1 Testing for gas tightness and purging

10.1.1 The gas installation needs to be tightness tested and purged in accordance with IGEM/UP/1, 1A or 1B as appropriate. This will depend on a combination of factors including the maximum diameter of pipework installed, the size of gas meter (where installed) and the total installation volume. Hydrostatic testing of TracPipe® or TracPipeCC® must not be undertaken due to the inherent risk of corrosion from the water used during the testing process and the inability to remove it completely from the corrugated construction of the pipe.

10.1.2 To calculate the internal volume of the TracPipe® / TracPipeCC® installation, the internal volumes outlined in Table 8 need to be used. The total installation volume will need to be calculated using an appropriate method outlined in the IGEM/UP/1 suite of standards.

Table 8 - TracPipe® and TracPipeCC® internal volumes

| Size (DN) | Volume of 1m length (m³) |
|---------------------|--------------------------|
| 12 (TracPipe® only) | 0.00013 |
| 15 | 0.00024 |
| 22 | 0.00046 |
| 28 | 0.00064 |
| 32 | 0.0011 |
| 40 | 0.0015 |
| 50 | 0.0024 |

10.1.3 It is important to note that some leak detection fluids (LDF) contain compounds that can be corrosive, either to stainless steel or to brass. Should the use of LDF's be necessary the operator must ensure that all traces are removed by washing with clean water. Household or 'washing up' liquid should **NOT** be used as leak detection fluid, as the high chloride content is corrosive to metals.

10.1.4 TracPipe® self-amalgamating silicon tape should be used to cover exposed stainless steel; it is essential that this is not applied until the pipework has been tested and deemed to be gas tight, (and any traces of LDF, if used, washed away and the pipe and fitting dried).

The tape should run over the whole of the back nut, leaving sufficient space to apply an earthing connection to the fitting body if required (see Clause 7.1.6).

10.2 Confirmation of adequacy of pipework sizing

10.2.1 When appliances are connected, it shall be confirmed that the pipework is adequate to ensure all appliances connected operate at their required heat input in accordance with the appliance manufacturer's instructions.

10.2.2 Due to the overall inaccuracies inherent in typical methods of on-site testing to confirm that the design pressure loss is achieved, a physical check of actual pressure losses between two specified points on an installation is not required.

10.2.3 Where there is a concern that there might be an excessive pressure loss, the operating pressure at the primary meter outlet, or where no meter is fitted, the regulator outlet, should be checked to confirm that this is within acceptable tolerances. Then, where a meter is installed a check should be carried out to confirm that the individual appliance(s) heat input is in accordance with the appliance manufacturers' specification. Where multiple appliances are installed this check should be repeated with all appliances in operation to confirm the

total of all appliance heat inputs is achieved. Where no meter is installed on an LPG installation, it is necessary to confirm the appliance(s) operating pressure is in accordance with the appliance manufacturers' specification with all appliances in operation.

Note: *Where it is not possible to carry out either a gas rating check or operating pressure check due to no gas meter being installed, reference should be made to Regulation 26(9)(ca) of the Gas Safety (Installation and Use) Regulations 1998 (as amended), or for Northern Ireland, HSE Certificate of Exemption No.1 2016, for which further guidance is given in Gas Safe Register Technical Bulletin 021(B) (available on the Gas Safe Register website www.gassaferegister.co.uk).*

In addition to confirming the appliance operating pressure or heat input or, where necessary, both, the combustion performance of the appliance should be checked with a suitable combustion performance analyser and confirmed to be within the tolerances laid down in the appliance manufacturers' instructions (where available) or BS 7967.

11 – Damage and Repair

11.1 General

Although TracPipe® and TracPipeCC® are very light, they have considerable hoop strength and will generally resist external damage better than copper. Further, provided it is not fixed too closely TracPipe® and TracPipeCC® have the natural ability to deflect away from nails, screws, drills and other implements of puncture.

If the tubing is damaged, refer to the following sections to determine the severity of damage and, if necessary, the method of repair.

11.2 Assessment

Repairs to the cover can be effected by the use of TracPipe® self-amalgamating silicon tape, as described earlier (see Clause 8.5.2).

No repairs or replacement of the tubing is necessary if the tubing is only slightly dented due to impact or crushing where the outside diameter is reduced by under a ⅓.

The tubing must be replaced under the following circumstances:

- A. The tubing has been significantly crushed or dented, where the outside diameter is reduced by more than a ⅓.
- B. The tubing has been damaged by puncture of any kind i.e. nails, screws, drill bits, etc.
- C. The tubing has been bent beyond its minimum bend radius so that a crease or kink remains.

11.3 Repair



A line splice can be made using two straight AutoFlare® fittings and a female malleable iron socket, or by using an AutoFlare® coupling. However, if the tubing run is short and easily accessible, the preferred repair is to replace the entire length. A tubing run can often be replaced faster than repairing the damaged section with a splice, and this does not add any additional fitting joints into the system.



The AutoFlare® fittings from the removed section can be reattached to the new tubing run.



AutoFlare® fittings cannot be buried or concealed within the fabric of the building and need to remain accessible.

12 - TracPipe® and TracPipeCC® System Components

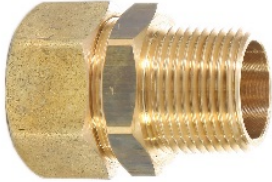
| Component | Material | Description/Dimensions | | | | | | | | | | | | | | | | | | | | | | | | | | | | | | | | |
|--|---|---|-----------|-----------|-----------|-----------|-----------|-----------|-----------|-------------|-------------|-----|-----|-------|-------|-------|-----------------------------|----|-----------------------------|----|----|----|----|-----------------------------|----|----|-----------------------------|----|----|----|----|----|----|----|
| TracPipe® Flexible Gas Piping | Corrugated Stainless Steel (1.4306) with Polyethylene Jacket | | | | | | | | | | | | | | | | | | | | | | | | | | | | | | | | | |
| | | <table border="1"> <tr> <td>DN</td> <td>12</td> <td>15</td> <td>22</td> <td>28</td> <td>32</td> <td>40</td> <td>50</td> </tr> <tr> <td>Inch</td> <td>3/8</td> <td>1/2</td> <td>3/4</td> <td>1</td> <td>1 1/4</td> <td>1 1/2</td> <td>2</td> </tr> <tr> <td>Jacket O.D. (max) mm</td> <td>17</td> <td>22</td> <td>28</td> <td>35</td> <td>42</td> <td>49</td> <td>66</td> </tr> <tr> <td>Inside Dia. (nom) mm</td> <td>11</td> <td>15</td> <td>21</td> <td>27</td> <td>33</td> <td>40</td> <td>52</td> </tr> </table> | DN | 12 | 15 | 22 | 28 | 32 | 40 | 50 | Inch | 3/8 | 1/2 | 3/4 | 1 | 1 1/4 | 1 1/2 | 2 | Jacket O.D. (max) mm | 17 | 22 | 28 | 35 | 42 | 49 | 66 | Inside Dia. (nom) mm | 11 | 15 | 21 | 27 | 33 | 40 | 52 |
| | | DN | 12 | 15 | 22 | 28 | 32 | 40 | 50 | | | | | | | | | | | | | | | | | | | | | | | | | |
| | | Inch | 3/8 | 1/2 | 3/4 | 1 | 1 1/4 | 1 1/2 | 2 | | | | | | | | | | | | | | | | | | | | | | | | | |
| | | Jacket O.D. (max) mm | 17 | 22 | 28 | 35 | 42 | 49 | 66 | | | | | | | | | | | | | | | | | | | | | | | | | |
| Inside Dia. (nom) mm | 11 | 15 | 21 | 27 | 33 | 40 | 52 | | | | | | | | | | | | | | | | | | | | | | | | | | | |
| | | | | | | | | | | | | | | | | | | | | | | | | | | | | | | | | | | |
| | | | | | | | | | | | | | | | | | | | | | | | | | | | | | | | | | | |
| TracPipeCC® Complete Containment Flexible Gas Piping | Corrugated Stainless Steel (1.4306) with Polyethylene Jackets | | | | | | | | | | | | | | | | | | | | | | | | | | | | | | | | | |
| | | <table border="1"> <tr> <td>DN</td> <td>15</td> <td>22</td> <td>28</td> <td>32</td> <td>40</td> <td>50</td> </tr> <tr> <td>Inch</td> <td>1/2</td> <td>3/4</td> <td>1</td> <td>1 1/4</td> <td>1 1/2</td> <td>2</td> </tr> <tr> <td>Jacket O.D. (max) mm</td> <td>25</td> <td>31</td> <td>38</td> <td>45</td> <td>52</td> <td>69</td> </tr> <tr> <td>Inside Dia. (nom) mm</td> <td>15</td> <td>21</td> <td>27</td> <td>33</td> <td>40</td> <td>52</td> </tr> </table> | DN | 15 | 22 | 28 | 32 | 40 | 50 | Inch | 1/2 | 3/4 | 1 | 1 1/4 | 1 1/2 | 2 | Jacket O.D. (max) mm | 25 | 31 | 38 | 45 | 52 | 69 | Inside Dia. (nom) mm | 15 | 21 | 27 | 33 | 40 | 52 | | | | |
| | | DN | 15 | 22 | 28 | 32 | 40 | 50 | | | | | | | | | | | | | | | | | | | | | | | | | | |
| | | Inch | 1/2 | 3/4 | 1 | 1 1/4 | 1 1/2 | 2 | | | | | | | | | | | | | | | | | | | | | | | | | | |
| | | Jacket O.D. (max) mm | 25 | 31 | 38 | 45 | 52 | 69 | | | | | | | | | | | | | | | | | | | | | | | | | | |
| Inside Dia. (nom) mm | 15 | 21 | 27 | 33 | 40 | 52 | | | | | | | | | | | | | | | | | | | | | | | | | | | | |
| | | | | | | | | | | | | | | | | | | | | | | | | | | | | | | | | | | |
| | | | | | | | | | | | | | | | | | | | | | | | | | | | | | | | | | | |

| <p>TracPipe® on Reels</p> | <p>Plywood Reels for Packaging</p> | <div style="text-align: center;">  </div> <table border="1" data-bbox="600 528 1380 1104"> <thead> <tr> <th>DN</th> <th>Reel Length (m)</th> <th>Approx. Weight (kg)</th> </tr> </thead> <tbody> <tr> <td rowspan="2">12</td> <td>30 metres</td> <td>7</td> </tr> <tr> <td>75 metres</td> <td>13.6</td> </tr> <tr> <td rowspan="2">15</td> <td>30 metres</td> <td>9</td> </tr> <tr> <td>75 metres</td> <td>21.5</td> </tr> <tr> <td rowspan="2">22</td> <td>30 metres</td> <td>12.5</td> </tr> <tr> <td>75 metres</td> <td>30.0</td> </tr> <tr> <td rowspan="3">28</td> <td>30 metres</td> <td>16.0</td> </tr> <tr> <td>55 metres</td> <td>29.0</td> </tr> <tr> <td>90 metres</td> <td>46.2</td> </tr> <tr> <td rowspan="2">32</td> <td>45 metres</td> <td>35.5</td> </tr> <tr> <td>75 metres</td> <td>57</td> </tr> <tr> <td rowspan="2">40</td> <td>45 metres</td> <td>38.0</td> </tr> <tr> <td>75 metres</td> <td>60.0</td> </tr> <tr> <td>50</td> <td>45 metres</td> <td>55.6</td> </tr> </tbody> </table> | DN | Reel Length (m) | Approx. Weight (kg) | 12 | 30 metres | 7 | 75 metres | 13.6 | 15 | 30 metres | 9 | 75 metres | 21.5 | 22 | 30 metres | 12.5 | 75 metres | 30.0 | 28 | 30 metres | 16.0 | 55 metres | 29.0 | 90 metres | 46.2 | 32 | 45 metres | 35.5 | 75 metres | 57 | 40 | 45 metres | 38.0 | 75 metres | 60.0 | 50 | 45 metres | 55.6 |
|-----------------------------|------------------------------------|--|----|-----------------|---------------------|----|-----------|------|-----------|------|----|-----------|------|-----------|------|----|-----------|------|-----------|------|-----------|-----------|------|-----------|------|-----------|------|----|-----------|------|-----------|------|----|-----------|------|-----------|------|----|-----------|------|
| DN | Reel Length (m) | Approx. Weight (kg) | | | | | | | | | | | | | | | | | | | | | | | | | | | | | | | | | | | | | | |
| 12 | 30 metres | 7 | | | | | | | | | | | | | | | | | | | | | | | | | | | | | | | | | | | | | | |
| | 75 metres | 13.6 | | | | | | | | | | | | | | | | | | | | | | | | | | | | | | | | | | | | | | |
| 15 | 30 metres | 9 | | | | | | | | | | | | | | | | | | | | | | | | | | | | | | | | | | | | | | |
| | 75 metres | 21.5 | | | | | | | | | | | | | | | | | | | | | | | | | | | | | | | | | | | | | | |
| 22 | 30 metres | 12.5 | | | | | | | | | | | | | | | | | | | | | | | | | | | | | | | | | | | | | | |
| | 75 metres | 30.0 | | | | | | | | | | | | | | | | | | | | | | | | | | | | | | | | | | | | | | |
| 28 | 30 metres | 16.0 | | | | | | | | | | | | | | | | | | | | | | | | | | | | | | | | | | | | | | |
| | 55 metres | 29.0 | | | | | | | | | | | | | | | | | | | | | | | | | | | | | | | | | | | | | | |
| | 90 metres | 46.2 | | | | | | | | | | | | | | | | | | | | | | | | | | | | | | | | | | | | | | |
| 32 | 45 metres | 35.5 | | | | | | | | | | | | | | | | | | | | | | | | | | | | | | | | | | | | | | |
| | 75 metres | 57 | | | | | | | | | | | | | | | | | | | | | | | | | | | | | | | | | | | | | | |
| 40 | 45 metres | 38.0 | | | | | | | | | | | | | | | | | | | | | | | | | | | | | | | | | | | | | | |
| | 75 metres | 60.0 | | | | | | | | | | | | | | | | | | | | | | | | | | | | | | | | | | | | | | |
| 50 | 45 metres | 55.6 | | | | | | | | | | | | | | | | | | | | | | | | | | | | | | | | | | | | | | |
| <p>TracPipeCC® on Reels</p> | <p>Plywood Reels for Packaging</p> | <div style="text-align: center;">  </div> <table border="1" data-bbox="600 1458 1380 1944"> <thead> <tr> <th>DN</th> <th>Reel Length (m)</th> <th>Approx. Weight (kg)</th> </tr> </thead> <tbody> <tr> <td rowspan="2">15</td> <td>30 metres</td> <td>11.5</td> </tr> <tr> <td>50 metres</td> <td>19.0</td> </tr> <tr> <td rowspan="2">22</td> <td>30 metres</td> <td>16.5</td> </tr> <tr> <td>75 metres</td> <td>39.0</td> </tr> <tr> <td rowspan="3">28</td> <td>30 metres</td> <td>22.0</td> </tr> <tr> <td>55 metres</td> <td>37.0</td> </tr> <tr> <td>90 metres</td> <td>59.0</td> </tr> <tr> <td rowspan="2">32</td> <td>45 metres</td> <td>44.0</td> </tr> <tr> <td>75 metres</td> <td>73.0</td> </tr> <tr> <td rowspan="2">40</td> <td>30 metres</td> <td>34.5</td> </tr> <tr> <td>60 metres</td> <td>66.5</td> </tr> <tr> <td>50</td> <td>40 metres</td> <td>64.5</td> </tr> </tbody> </table> | DN | Reel Length (m) | Approx. Weight (kg) | 15 | 30 metres | 11.5 | 50 metres | 19.0 | 22 | 30 metres | 16.5 | 75 metres | 39.0 | 28 | 30 metres | 22.0 | 55 metres | 37.0 | 90 metres | 59.0 | 32 | 45 metres | 44.0 | 75 metres | 73.0 | 40 | 30 metres | 34.5 | 60 metres | 66.5 | 50 | 40 metres | 64.5 | | | | | |
| DN | Reel Length (m) | Approx. Weight (kg) | | | | | | | | | | | | | | | | | | | | | | | | | | | | | | | | | | | | | | |
| 15 | 30 metres | 11.5 | | | | | | | | | | | | | | | | | | | | | | | | | | | | | | | | | | | | | | |
| | 50 metres | 19.0 | | | | | | | | | | | | | | | | | | | | | | | | | | | | | | | | | | | | | | |
| 22 | 30 metres | 16.5 | | | | | | | | | | | | | | | | | | | | | | | | | | | | | | | | | | | | | | |
| | 75 metres | 39.0 | | | | | | | | | | | | | | | | | | | | | | | | | | | | | | | | | | | | | | |
| 28 | 30 metres | 22.0 | | | | | | | | | | | | | | | | | | | | | | | | | | | | | | | | | | | | | | |
| | 55 metres | 37.0 | | | | | | | | | | | | | | | | | | | | | | | | | | | | | | | | | | | | | | |
| | 90 metres | 59.0 | | | | | | | | | | | | | | | | | | | | | | | | | | | | | | | | | | | | | | |
| 32 | 45 metres | 44.0 | | | | | | | | | | | | | | | | | | | | | | | | | | | | | | | | | | | | | | |
| | 75 metres | 73.0 | | | | | | | | | | | | | | | | | | | | | | | | | | | | | | | | | | | | | | |
| 40 | 30 metres | 34.5 | | | | | | | | | | | | | | | | | | | | | | | | | | | | | | | | | | | | | | |
| | 60 metres | 66.5 | | | | | | | | | | | | | | | | | | | | | | | | | | | | | | | | | | | | | | |
| 50 | 40 metres | 64.5 | | | | | | | | | | | | | | | | | | | | | | | | | | | | | | | | | | | | | | |

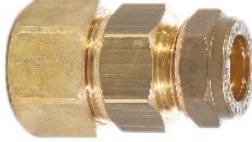
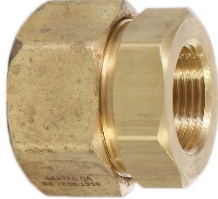
| Component | Material | Description/Dimensions | | | | | | | | | | | | | | | | | | | | | | | | | |
|--|---|---|-----------------|-----------------|-----------------|-----------------|-----------------|--|-----------------|-----------------|-----------------|-----------------|--|-----------------|-----------------|-----------------|-----------------|----|------|------|------|------|----|------|------|------|------|
| TracPipe® KITS | Boxed in a cardboard box. Complete with fitting instructions and a roll of silicone tape. | <div style="text-align: center;">  </div> <table border="1" data-bbox="587 831 1385 1093"> <thead> <tr> <th>Part No.</th> <th>FGP-15-05 (kit)</th> <th>FGP-22-05 (kit)</th> <th>FGP-28-05 (kit)</th> <th>FGP-32-05 (kit)</th> </tr> </thead> <tbody> <tr> <td></td> <td>FGP-15-10 (kit)</td> <td>FGP-22-10 (kit)</td> <td>FGP-28-10 (kit)</td> <td>FGP-32-10 (kit)</td> </tr> <tr> <td></td> <td>FGP-15-15 (kit)</td> <td>FGP-22-15 (kit)</td> <td>FGP-28-15 (kit)</td> <td>FGP-32-15 (kit)</td> </tr> <tr> <td>DN</td> <td>15mm</td> <td>21mm</td> <td>26mm</td> <td>33mm</td> </tr> <tr> <td>DN</td> <td>22mm</td> <td>28mm</td> <td>35mm</td> <td>42mm</td> </tr> </tbody> </table> <p>5Mtr, 10Mtr or 15Mtr length's supplied with (kit) or without AutoFlare® fittings.</p> | Part No. | FGP-15-05 (kit) | FGP-22-05 (kit) | FGP-28-05 (kit) | FGP-32-05 (kit) | | FGP-15-10 (kit) | FGP-22-10 (kit) | FGP-28-10 (kit) | FGP-32-10 (kit) | | FGP-15-15 (kit) | FGP-22-15 (kit) | FGP-28-15 (kit) | FGP-32-15 (kit) | DN | 15mm | 21mm | 26mm | 33mm | DN | 22mm | 28mm | 35mm | 42mm |
| Part No. | FGP-15-05 (kit) | FGP-22-05 (kit) | FGP-28-05 (kit) | FGP-32-05 (kit) | | | | | | | | | | | | | | | | | | | | | | | |
| | FGP-15-10 (kit) | FGP-22-10 (kit) | FGP-28-10 (kit) | FGP-32-10 (kit) | | | | | | | | | | | | | | | | | | | | | | | |
| | FGP-15-15 (kit) | FGP-22-15 (kit) | FGP-28-15 (kit) | FGP-32-15 (kit) | | | | | | | | | | | | | | | | | | | | | | | |
| DN | 15mm | 21mm | 26mm | 33mm | | | | | | | | | | | | | | | | | | | | | | | |
| DN | 22mm | 28mm | 35mm | 42mm | | | | | | | | | | | | | | | | | | | | | | | |
| AutoFlare® Straight Mechanical Fitting | Brass Fitting AutoFlare® Insert | <div style="text-align: center;">  </div> <p style="text-align: center;">Sizes DN10, 15, 22, 28, 32, 40 and 50</p> | | | | | | | | | | | | | | | | | | | | | | | | | |
| AutoFlare® Tee Fitting and Coupling | Brass Fitting AutoFlare® Insert | <div style="text-align: center;">  </div> <p style="text-align: center;">Sizes DN10, 15, 22, 28, 32, 40 and 50</p> | | | | | | | | | | | | | | | | | | | | | | | | | |

| Component | Material | Description/Dimensions | | | | | | | | | | | | | | | | | | |
|---|--|--|-------------------------------------|------------------|---------------|-------------------------------------|---------------|-------------------------------------|---------------|-------------------------------------|---------------|-------------------------------------|---------------|-------------------------------------|-------------|--------------------------------------|-------------|-------------------------------------|-------------|-------------------------------------|
| TracPipe® / TracPipeCC® to Copper Compression | Brass Fitting AutoFlare® Insert Copper Olive |  | | | | | | | | | | | | | | | | | | |
| | | <table border="1"> <thead> <tr> <th>Part No.</th> <th>Part Description</th> </tr> </thead> <tbody> <tr> <td>FGP-15x15mm</td> <td>15mm Compression for DN15 TracPipe®</td> </tr> <tr> <td>FGP-22x15mm</td> <td>15mm Compression for DN22 TracPipe®</td> </tr> <tr> <td>FGP-22x22mm</td> <td>22mm Compression for DN22 TracPipe®</td> </tr> <tr> <td>FGP-28x22mm</td> <td>22mm Compression for DN28 TracPipe®</td> </tr> <tr> <td>FGP-28x28mm</td> <td>28mm Compression for DN28 TracPipe®</td> </tr> <tr> <td>FGP-32x22mm</td> <td>22mm Compression for DN32 TracPipe®</td> </tr> <tr> <td>FGP-32x28mm</td> <td>28mm Compression for DN32 TracPipe®</td> </tr> <tr> <td>FGP-32x35mm</td> <td>35mm Compression for DN32 TracPipe®</td> </tr> </tbody> </table> | Part No. | Part Description | FGP-15x15mm | 15mm Compression for DN15 TracPipe® | FGP-22x15mm | 15mm Compression for DN22 TracPipe® | FGP-22x22mm | 22mm Compression for DN22 TracPipe® | FGP-28x22mm | 22mm Compression for DN28 TracPipe® | FGP-28x28mm | 28mm Compression for DN28 TracPipe® | FGP-32x22mm | 22mm Compression for DN32 TracPipe® | FGP-32x28mm | 28mm Compression for DN32 TracPipe® | FGP-32x35mm | 35mm Compression for DN32 TracPipe® |
| | | Part No. | Part Description | | | | | | | | | | | | | | | | | |
| | | FGP-15x15mm | 15mm Compression for DN15 TracPipe® | | | | | | | | | | | | | | | | | |
| | | FGP-22x15mm | 15mm Compression for DN22 TracPipe® | | | | | | | | | | | | | | | | | |
| | | FGP-22x22mm | 22mm Compression for DN22 TracPipe® | | | | | | | | | | | | | | | | | |
| | | FGP-28x22mm | 22mm Compression for DN28 TracPipe® | | | | | | | | | | | | | | | | | |
| | | FGP-28x28mm | 28mm Compression for DN28 TracPipe® | | | | | | | | | | | | | | | | | |
| | | FGP-32x22mm | 22mm Compression for DN32 TracPipe® | | | | | | | | | | | | | | | | | |
| FGP-32x28mm | 28mm Compression for DN32 TracPipe® | | | | | | | | | | | | | | | | | | | |
| FGP-32x35mm | 35mm Compression for DN32 TracPipe® | | | | | | | | | | | | | | | | | | | |
| TracPipe® to BSP Female BSP Thread | Brass Fitting AutoFlare® Insert |  | | | | | | | | | | | | | | | | | | |
| | | <table border="1"> <thead> <tr> <th>Part No.</th> <th>Part Description</th> </tr> </thead> <tbody> <tr> <td>FGP-22-500BSP</td> <td>1/2" BSP female for DN22 TracPipe®</td> </tr> <tr> <td>FGP-22-750BSP</td> <td>3/4" BSP female for DN22 TracPipe®</td> </tr> <tr> <td>FGP-28-500BSP</td> <td>1/2" BSP female for DN28 TracPipe®</td> </tr> <tr> <td>FGP-28-750BSP</td> <td>3/4" BSP female for DN28 TracPipe®</td> </tr> <tr> <td>FGP-32-750BSP</td> <td>3/4" BSP female for DN32 TracPipe®</td> </tr> <tr> <td>FGP-FSTF-50</td> <td>AutoFlare® female straight DN50 x 2"</td> </tr> </tbody> </table> | Part No. | Part Description | FGP-22-500BSP | 1/2" BSP female for DN22 TracPipe® | FGP-22-750BSP | 3/4" BSP female for DN22 TracPipe® | FGP-28-500BSP | 1/2" BSP female for DN28 TracPipe® | FGP-28-750BSP | 3/4" BSP female for DN28 TracPipe® | FGP-32-750BSP | 3/4" BSP female for DN32 TracPipe® | FGP-FSTF-50 | AutoFlare® female straight DN50 x 2" | | | | |
| | | Part No. | Part Description | | | | | | | | | | | | | | | | | |
| | | FGP-22-500BSP | 1/2" BSP female for DN22 TracPipe® | | | | | | | | | | | | | | | | | |
| | | FGP-22-750BSP | 3/4" BSP female for DN22 TracPipe® | | | | | | | | | | | | | | | | | |
| | | FGP-28-500BSP | 1/2" BSP female for DN28 TracPipe® | | | | | | | | | | | | | | | | | |
| | | FGP-28-750BSP | 3/4" BSP female for DN28 TracPipe® | | | | | | | | | | | | | | | | | |
| FGP-32-750BSP | 3/4" BSP female for DN32 TracPipe® | | | | | | | | | | | | | | | | | | | |
| FGP-FSTF-50 | AutoFlare® female straight DN50 x 2" | | | | | | | | | | | | | | | | | | | |
| TracPipe® / TracPipeCC® Elbow To Copper Compression | Brass Fitting AutoFlare® Insert Copper Olive |  | | | | | | | | | | | | | | | | | | |
| | | <p>DN22 and DN28 Only</p> | | | | | | | | | | | | | | | | | | |

| Component | Material | Description/Dimensions | |
|------------------------------------|---|--|---|
| TracPipe® / TracPipeCC® Tape | Silicone |  | |
| | | Part No. | Part Description |
| | | FGP-915-10H-12 | Silicone Tape Yellow 25mm wide (11m Roll) |
| FGP-915-20H12PO | Silicone Tape Yellow 50mm wide (11m Roll) | | |

Annex A – Essential Information (Normative)

A.1 Installation procedures

The installation pipework should be installed in accordance with the manufacturer's instructions with due regard also given to BS 6891, or the Institution of Gas Engineers and Managers publications IGEM/UP/2 Latest Edition, and tested in accordance with IGE/UP/1, IGE/UP/1A or IGE/UP/1B as appropriate,.

When designing and planning the installation, consideration should be given to the possibility of restricted access on site and the forces and torques required for assembly, particularly for the larger diameters.

A.2 Compatible products

Corrugated pipe from a particular manufacturer must be assembled only using fittings supplied or specified by the same manufacturer and must not be assembled using fittings from other sources.

A.3 Pipe sizes

Sizing of installation pipework can be carried out in accordance with BS 6891 or IGEM/UP/2 Latest Edition as appropriate. For the TracPipe® and TracPipeCC® parts of the installation, sizing can be carried out in accordance with the specific data contained in Annex F.

A.4 Pipe supports and appliance connection

Pliable corrugated stainless steel tube should not be used where during installation, or subsequent to installation, it can be subjected to vibration or repeated bending. Pliable corrugated stainless steel tube is an alternative to rigid pipe systems, not a replacement for flexible connections.

Installation pipework must be adequately supported in accordance with the requirements of the manufacturer's instructions (see Clause 8.12 and Table 4), BS 6891 and IGEM/UP/2 Latest Edition as appropriate.

A movable appliance (e.g. cooker, tumble dryer) must not be connected directly to pliable corrugated stainless steel tubing. Connection should be made using a flexible connector in accordance with BS 669-1, BS 669-2 or BS EN 14800 or BS EN 15069 as appropriate.

Some types of overhead heaters are not considered as moveable appliances and TracPipe® or TracPipeCC® can be connected directly to these units. However, where the heater manufacturer specifies that a flexible connection must be used, TracPipe® and TracPipeCC® are **NOT** a replacement for a flexible hose.

The length of unsupported corrugated pipe connected directly to any fixed appliance should not exceed 500mm. Where the final connection is made indirectly by using a length of rigid pipe, the end fittings or adaptor should be permanently fixed. If the appliance is normally moved for servicing, an isolation valve and a union coupling or other suitable means of disconnection should be fitted at the appliance inlet.

During assembly or disassembly, manifolds if used, should be adequately supported by wrenches or other means, to avoid excessive strain on fittings or attached pipework.

A.5 Connections to copper pipe

It is important that TracPipe® and TracPipeCC® are not contaminated in any way with flux or solder, either internally or externally. Any soldering on adjacent copper pipework must be completed, and the soldered component thoroughly cleaned of flux, before any connection to TracPipe® or TracPipeCC® is made.

Annex B – Guide to Sizing Gas Supplies (Normative)

When deciding on the correct size of gas installation pipework, it is recommended practice to allow a maximum design pressure loss between the point of supply and the appliance connection points (see Clause 5 *Sizing* for specific requirements).

Figure B.1 gives an example of a typical natural gas TracPipe® or TracPipeCC® installation showing the lengths of pipes and the gas rates of the appliances. The pipes have been sized using Tables G4 and G7 of Annex F, and the results are shown in Table B.1. When sizing pipes, it is essential that consideration is given to the permissible pressure loss in each section of the installation. For example, as this is a natural gas installation, the design pressure loss between A and H in Figure B.1 should not exceed 1mbar.

Figure B.1

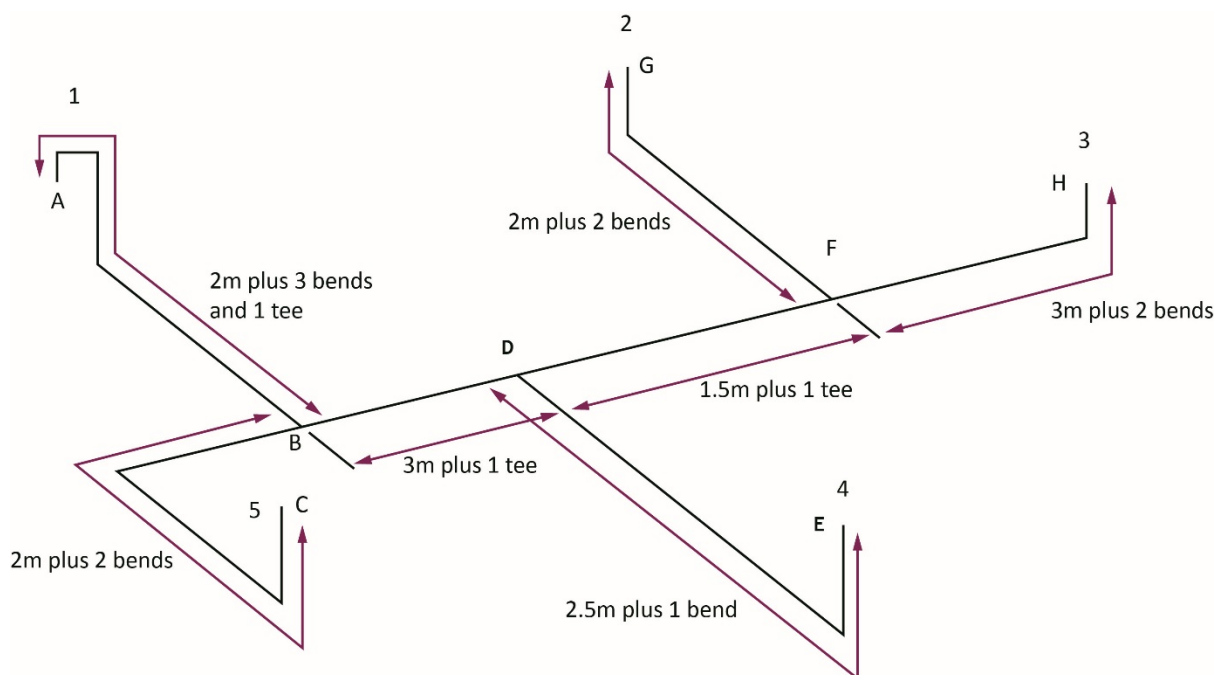

Key to Figure B.1

- | | |
|----------------|----------------------|
| 1 Meter | 4 Combination boiler |
| 2 Hob | 5 Inset gas fire |
| 3 Tumble dryer | |

| Appliance | Gas rate (typical) m ³ /hr |
|--------------------|---------------------------------------|
| Hob | 1.0 |
| Tumble Dryer | 0.5 |
| Combination Boiler | 3.0 |
| Inset gas fire | 0.75 |

A to H is made up of four sections of pipe, A-B, B-D, D-F and F-H. Each section carries a different gas rate and needs to be sized separately.

If A to H is to have a design pressure loss of not more than 1mbar, then the pressure losses in each of the four sections should be sized so the total of the pressure losses across each section does not exceed the maximum design pressure loss allowed.

The data contained in Table G4 offers a pressure drop per metre of pipe depending on how much gas is flowing through that pipe.

The data in Table G7 outlines the equivalent length that needs to be added for bends, tees, etc. All bends should be included in the section of the run to be calculated. When allowing for a tee, it should be included at the end of the run being calculated.

Example B.1

Considering length B – D as given in Figure B.1:

B – D has a length of 3m and is to carry a gas rate of 4.5m³/hr. There are no bends and one tee on this section of pipework (at the end of the run). Therefore the equivalent length of the section will be 3m plus one tee. Looking at Table G7, it depends on the size of the pipe as to how much equivalent length is added for a tee. It is estimated the maximum size needed for this section of pipework will be DN28 therefore an equivalent length of 0.5m will need to be added. This makes the total equivalent length for section B – D 3.5m.

From looking at Table G4, select the gas rate of 4.5m³/hr from the left hand column and then select the corresponding figure below DN28. The figure at this point is 0.0563. You then multiply 0.0563 x 3.5 (total equivalent length) which equates to 0.2mbar.

The other sections will be calculated in the same way ensuring the total design pressure loss does not exceed 1mbar for the natural gas installation.

See Table B.1 for completed sizing design for this example.

Table B.1 – Completed sizing design - example

| Pipework section | Maximum flow rate m ³ /hr | Estimated pipe size DN | Pipe Length m | Fittings allowance | | Adjusted length m | Pressure loss/metre m | Section pressure loss mbar |
|------------------|---|---------------------------|------------------|---------------------|------------------------|----------------------|--------------------------|-------------------------------|
| | | | | Type | Equivalent length m | | | |
| A - B | 5.25 | 28 | 2 | Bend x 3 Tee x 1 | 0.9 0.5 | 3.4 | 0.0771 | 0.26 |
| B – C | 0.75 | 15 | 4 | Bend x 2 | 0.6 | 4.6 | 0.0266 | 0.1 |
| B – D | 4.5 | 28 | 3 | Tee x 1 | 0.5 | 3.5 | 0.0563 | 0.25 |
| D – E | 3 | 22 | 2.5 | Bend x 1 | 0.3 | 2.8 | 0.0725 | 0.2 |
| D – F | 1.5 | 22 | 1.5 | Tee x 1 | 0.5 | 2 | 0.0175 | 0.03 |
| F – G | 1 | 15 | 2 | Bend x 2 | 0.6 | 2.6 | 0.0482 | 0.1 |
| F – H | 0.5 | 15 | 3 | Bend x 2 | 0.6 | 3.6 | 0.0115 | 0.04 |

| Appliance | Maximum flow rate m ³ /hr | Pipework sections and associated pressure loss | | | | Total pressure loss mbar | Satisfactory? |
|--------------------|---|--|---------------|---------------|---------------|-----------------------------|---------------|
| | | A - B mbar | B - D mbar | D - F mbar | F - G mbar | | |
| Hob | 1 | 0.26 | 0.2 | 0.03 | 0.1 | 0.59 | Yes |
| Tumble Dryer | 0.5 | 0.26 | 0.2 | 0.03 | 0.04 | 0.53 | Yes |
| Combination Boiler | 3 | 0.26 | 0.2 | 0.2 | - | 0.66 | Yes |
| Inset gas fire | 0.75 | 0.26 | 0.1 | - | - | 0.36 | Yes |

Example B.2

As TracPipe® AutoFlare® fittings cannot be concealed within the fabric of the building, designing an installation shown in example B.1 is not always practical. Therefore an alternative would be to utilise a manifold installation (see Figure B.2). This allows the manifold to be located in a central position and then single pipe runs installed to supply each individual appliance.

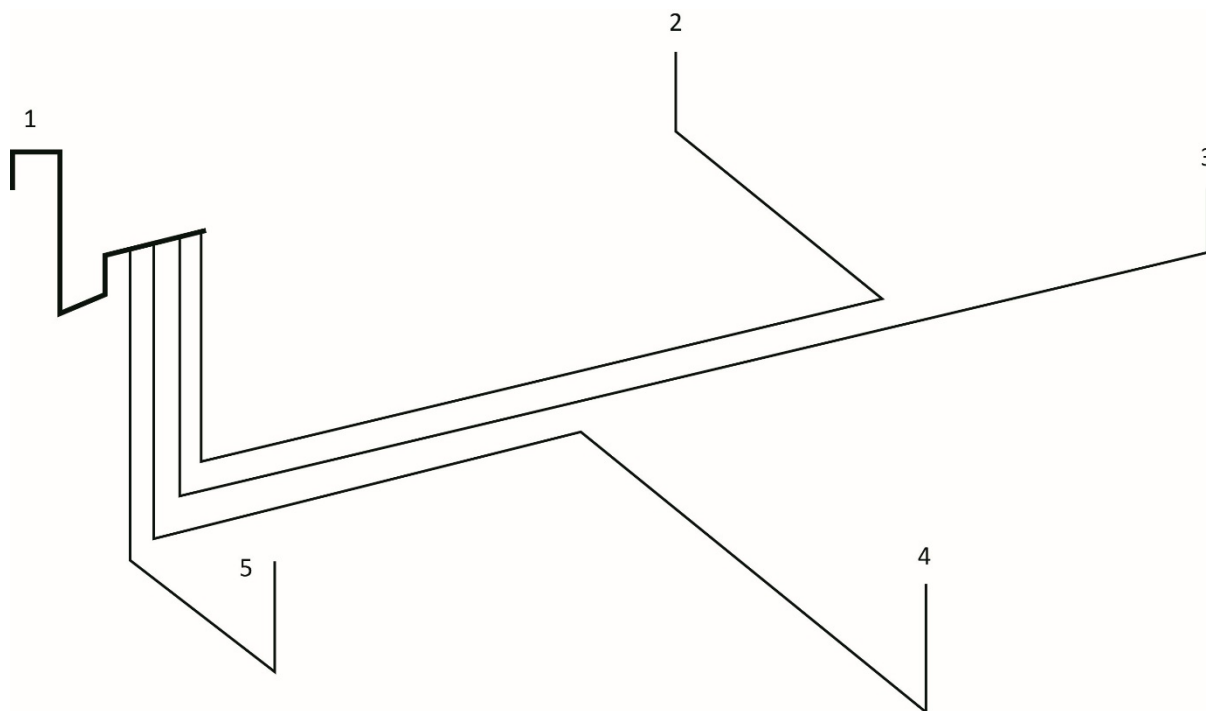

Key to Figure B.2

- | | |
|----------------|----------------------|
| 1 Meter | 4 Combination boiler |
| 2 Hob | 5 Inset gas fire |
| 3 Tumble dryer | |

The lengths are as follows:

Meter to manifold – 1m + 5 bends = 2.5m equivalent length

Manifold – Comprises of 4 x Tee's = 2m equivalent length

Manifold to hob – 6.5m + 3 bends = 7.4m equivalent length

Manifold to tumble dryer – 8.5m + 2 bends = 9.1m equivalent length

Manifold to combination boiler – 6.5m + 3 bends = 7.4m equivalent length

Manifold to inset gas fire – 3m + 2 bends = 3.6m equivalent length

Table B.2 – Completed sizing design (Manifold) - example

| Pipework section | | Maximum flow rate m ³ /hr | Estimated pipe size DN | Pipe Length m | Fittings allowance | | Adjusted length m | Pressure loss/metre m | Section pressure loss mbar |
|------------------|--------------------------|---|---------------------------|------------------|--------------------|------------------------|----------------------|--------------------------|-------------------------------|
| | | | | | Type | Equivalent length m | | | |
| 1 | Meter to Manifold | 5.25 | 28 | 1 | Bend x 5 | 1.5 | 2.5 | 0.0771 | 0.19 |
| 2 | Manifold | 5.25 | 28 | 0 | Tee x 4 | 2.0 | 2.0 | 0.0771 | 0.15 |
| 3 | Manifold to hob | 1 | 15 | 6.5 | Bend x 3 | 0.9 | 7.4 | 0.0482 | 0.36 |
| 4 | Manifold to tumble dryer | 0.5 | 15 | 8.5 | Bend x 2 | 0.6 | 9.1 | 0.0115 | 0.1 |
| 5 | Manifold to combi boiler | 3 | 22 | 6.5 | Bend x 3 | 0.9 | 7.4 | 0.0725 | 0.54 |
| 6 | Manifold to fire | 0.75 | 15 | 3 | Bend x 3 | 0.9 | 3.9 | 0.0266 | 0.1 |

| Appliance | Maximum flow rate m ³ /hr | Pipework sections and associated pressure loss | | | | Total pressure loss mbar | Satisfactory? |
|--------------------|---|--|------|------|------|-----------------------------|---------------|
| | | mbar | | | | | |
| Hob | 1 | 1 | 2 | 3 | 0.59 | Yes | |
| | | 0.19 | 0.15 | 0.25 | | | |
| Tumble Dryer | 0.5 | 1 | 2 | 4 | 0.44 | Yes | |
| | | 0.19 | 0.15 | 0.1 | | | |
| Combination Boiler | 3 | 1 | 2 | 5 | 0.88 | Yes | |
| | | 0.19 | 0.15 | 0.54 | | | |
| Inset gas fire | 0.75 | 1 | 2 | 6 | 0.44 | Yes | |
| | | 0.19 | 0.15 | 0.1 | | | |

Annex C – Definitions (Informative)

For the purposes of this Document the definitions given in BS 1179: Part 6: 1980 apply, together with the following.

C.1 Additional emergency control valve (AECV)

A valve, not being the ECV, for shutting off the supply of gas in an emergency, intended for use by a consumer of gas.

Note: An AECV may not isolate all of the consumer's pipework or meter installation.

C.2 Compartment Floor

Floor that separates one dwelling from the rest of the building

C.3 Duct

Enclosed space specifically designed and constructed for the passage of building services

C.4 Emergency control valve (ECV)

A valve, not being an additional emergency control valve (AECV), for shutting off the supply of gas in an emergency, intended for use by a consumer of gas, and being installed at the end of a service or distribution main.

C.5 Installation pipework

Pipework or fitting from the outlet of the primary meter installation or, for LPG installations where no meter is fitted, the outlet of the ECV to points at which appliances/equipment are to be connected

Note: This definition varies from that given in the Gas Safety (Installation and Use) Regulations 1998. This term does not refer to:

- a) a service (pipe) or distribution main or other pipeline;
- b) a pipe or fitting forming part of a gas appliance;
- c) a pipe or fitting within a primary meter installation; or
- d) any valve attached to a storage container or cylinder.

C.6 Intermediate floor

Floor that separates one living space from another living space in the same dwelling.

Note: This is not a compartment floor that separates one dwelling from another part of the building.

C.7 Normally occupied

The term "normally occupied" means an individual dwelling or an area in which it is reasonably expected that passers-by will be in the vicinity, e.g. regularly used common corridors or common lobbies.

C.8 Primary meter

The meter nearest to and downstream of a service pipe or service pipework for ascertaining the volume of gas supplied through that pipe by a gas supplier.

C.9 Protected corridor/lobbyEngland, Wales and Northern Ireland

A corridor or lobby which is adequately protected from fire in adjoining accommodation by fire-resisting construction.

Scotland

A lobby within a protected zone but separated from the remainder of the protected zone so as to resist the movement of smoke from the adjoining accommodation to the remainder of the protected zone.

C.10 Protected shaft

Ventilated space containing gas pipework, and isolated from other parts of a building within fire-resisting construction, which includes:

- a) a common stairway, corridor or lobby that provides an escape route from a building to a place of safety and access for fire fighting purposes (referred to within Building Regulations as a “protected shaft”, “protected stairway”, “protected corridor/lobby” or “protected zone”);
- b) a service shaft/duct, which may also contain electrical and water services.

Note: Fire resisting is the ability of a component or construction of a building to satisfy for a stated period of time, some or all of the appropriate criteria specified in the relevant part of BS 476. Additional guidance on determining whether an area can be deemed a “protected area” or otherwise is given in BS 6891: 2015 Annex D.

C.11 Range-rated appliance

Appliance that has the facility for an operative to adjust the heat input of the appliance within a narrow range of minimum and maximum heat inputs stated by the manufacturer to suit the actual heat requirements of the system

Note: The range between minimum and maximum heat inputs is in the region of 3kW.

C.12 Service pipe

Pipe for distributing gas to premises from a distribution main, being any pipe between the distribution main and the outlet of the first emergency control valve.

C.13 Service pipework

Pipe for supplying gas to premises from a gas storage vessel, being any pipe between the gas storage vessel and the outlet of the ECV.

C.14 Sleeve

Protective pipe forming an annulus embedded in the structure through which pipework can be inserted and withdrawn

C.15 Variable-rated appliance

Appliance that has the facility for an operative to set the heat input of the appliance within a wide range of heat inputs stated by the manufacturer to suit the actual heat requirements of the system

Annex D – Sample Specification (Informative)

TracPipe® and TracPipeCC® corrugated stainless steel semi-rigid pipe and associated fittings for low-pressure gas pipework – SAMPLE SPECIFICATION.

Gas Piping

The gas piping material shall be Corrugated Stainless Steel Semi-rigid pipe Kitemarked to British Standard BS EN 15266 and installed in accordance with British Standards BS 6891: 2015 and Institution of Gas Engineers and Managers publication IGEM/UP/2 Latest Edition in other premises.

The stainless steel tubing should not be annealed after forming to ensure maximum crush resistance, and the attachment fittings must have a metal-to-metal seat to accomplish gas sealing. Elastomeric seal rings or fibre gaskets are not permitted in the tubing attachment fittings.

A non-metallic outer cover, coloured yellow, and marked 'GAS', of non-halogenated, fire and smoke retardant polyethylene with a EUROCLASS classification of B – s1, d0 shall be used. Polyvinyl chloride (PVC) is not permitted as an outer cover material. The outer cover shall be a minimum of 0.5mm thick and have a maximum chloride content of 50ppm.

Where piping penetrates floor slabs evidence of a minimum 2-hour fire rating is required for the gas piping material.

The gas piping material shall satisfy the requirements in BS 6891 or IGEM/UP/2 Latest Edition for sleeved pipe, such that the piping can pass through unventilated voids, without joints, whilst maintaining its sleeved integrity.

For timber frame housing, (refer to IGE/UP/7 Latest Edition), the sleeving must be maintained, as above, without joints, where the pipework passes through unventilated voids in the construction.

Type TracPipe® and TracPipeCC® semi-rigid gas piping is available from OmegaFlex Limited, Kildare House, Wildmere Road, Banbury, Oxfordshire OX16 3JU – U.K.

Tel: 01295 676670 (Int + 44 1295 67 66 70.)

Fax: 01295 267302 (Int + 44 1295 26 73 02.)

Email: eurosales@omegaflex.com / Tech-Help@omegaflex.com

Web: www.tracpipe.co.uk

Annex E – Pipe Cutter and Secondary Containments (Informative)

Pipe Cutter

When TracPipe® is being cut to permit the attachment of end fittings, all sizes must always be cut with a wheeled pipe cutter with a sharp steel wheel. For sizes up to DN28, many different makes and models of pipe cutter are suitable. For larger sizes, some makes and models of pipe cutter may be unsuitable. For sizes up to DN28, we recommend a Ridgid model 151 (FGP-TC-151). For all sizes up to DN50, we recommend Ridgid model 152 (FGP-TC-152), using cutting wheel FGP-E-5272.

CAUTION: Use of a small cutting wheel may flatten the first corrugation and make sealing of fittings difficult.

Installation of TracPipe® within a secondary containment

We are sometimes asked for recommendations for additional piping (or secondary containment) to enclose TracPipe® when running through unventilated enclosures, ducts or voids. **In the first instance we would always recommend investigating to see if TracPipeCC® can be used as an alternative solution or, if this is not possible, if the space or void can be adequately ventilated (see 8.8.3).**

If a secondary containment is required, it should be of a material impermeable to gas (see 8.7 *Sleeves*) and should be in a continuous length (without joints). **Gas installation pipework installed within a secondary containment duct would not be suitable for vertical runs as it is not possible to adequately support that internal run of pipework as required by the appropriate standards.**

Note: TracPipeCC®, due to the unique patented design of the product, can be installed both horizontally and vertically and therefore overcomes the issues with needing to adequately ventilate vertical sections, such as service risers (see Clause 8.8.3).

Where the secondary containment passes through compartment walls and floors, it needs to be appropriately fire-stopped, typically with a suitably sized intumescent collar (or similar).

The material of the secondary containment duct, (which is often vented to atmosphere), is sometimes specified, in which case either follow the specification or contact our Technical Services Team for additional information on tel: 01295 676670 or at Tech-Help@omegaflex.com

It is recommended that you discuss the suitability of any sleeving intended to be used as a secondary containment with the product manufacturer, Building Control, Gas Safe Register and those responsible for the overall building design where necessary as we are not in a position to offer any guarantee to its suitability for the intended application.

Annex F – Sizing Tables for TracPipe®/TracPipeCC® (Informative)

Persons designing gas installation pipework systems with the data contained in this Annex will need to use an appropriate sizing method.

Note: *Examples of suitable sizing methods are outlined in Annex B.*

Annex F – Sizing Tables for TracPipe®/TracPipeCC® (Informative)

TABLE F1 - Approximate discharge through TracPipe®/TracPipeCC® CSST in cubic metres per hour for NATURAL GAS (relative density 0.60)

| | | Inlet Pressure: 21 mbar Pressure Drop: 1 mbar Specific Gravity (Relative Density) of Gas: 0.60 | | | | | | | | | | | | | | | | | | | |
|----|-----|--|-------|-------|-------|-------|-------|-------|-------|-------|-------|-------|-------|-------|-------|-------|-------|-------|-------|-------|-------|
| | | Tubing Length (metres) | | | | | | | | | | | | | | | | | | | |
| DN | EHD | 3 | 6 | 9 | 12 | 15 | 20 | 25 | 30 | 40 | 50 | 60 | 70 | 80 | 90 | 100 | 110 | 120 | 130 | 140 | 150 |
| 12 | 15 | 1.18 | 0.85 | 0.70 | 0.62 | 0.55 | 0.49 | 0.44 | 0.40 | 0.35 | 0.32 | 0.29 | 0.27 | 0.25 | 0.24 | 0.23 | 0.22 | 0.21 | 0.20 | 0.20 | 0.19 |
| 15 | 19 | 2.55 | 1.82 | 1.50 | 1.30 | 1.17 | 1.02 | 0.91 | 0.84 | 0.73 | 0.65 | 0.60 | 0.56 | 0.52 | 0.49 | 0.47 | 0.45 | 0.43 | 0.41 | 0.40 | 0.38 |
| 22 | 25 | 6.30 | 4.50 | 3.69 | 3.21 | 2.88 | 2.50 | 2.25 | 2.05 | 1.79 | 1.60 | 1.47 | 1.36 | 1.27 | 1.20 | 1.14 | 1.09 | 1.05 | 1.01 | 0.97 | 0.94 |
| 28 | 31 | 10.76 | 7.66 | 6.28 | 5.46 | 4.89 | 4.25 | 3.81 | 3.48 | 3.02 | 2.71 | 2.48 | 2.30 | 2.15 | 2.03 | 1.93 | 1.84 | 1.76 | 1.70 | 1.64 | 1.58 |
| 32 | 37 | 20.24 | 14.40 | 11.80 | 10.25 | 9.18 | 7.97 | 7.14 | 6.53 | 5.67 | 5.08 | 4.65 | 4.31 | 4.04 | 3.81 | 3.62 | 3.45 | 3.31 | 3.18 | 3.07 | 2.96 |
| 40 | 46 | 32.25 | 22.72 | 18.51 | 16.01 | 14.30 | 12.37 | 11.05 | 10.08 | 8.71 | 7.78 | 7.10 | 6.57 | 6.14 | 5.78 | 5.48 | 5.23 | 5.00 | 4.80 | 4.63 | 4.47 |
| 50 | 62 | 75.14 | 53.23 | 43.51 | 37.71 | 33.75 | 29.25 | 26.18 | 23.91 | 20.72 | 18.55 | 16.94 | 15.69 | 14.68 | 13.85 | 13.14 | 12.53 | 12.00 | 11.53 | 11.11 | 10.74 |

Notes: 1) Flow rates based on Standard Conditions of 21C and 1 bar.
 2) Flow rates above include losses for four 90-degree bends and two end fittings. For tubing runs with additional bends or fittings, increase pipe length by the values given in Table F7.

TABLE F2 - Approximate discharge through TracPipe®/TracPipeCC® CSST in cubic metres per hour for PROPANE (relative density 1.52)

| | | Inlet Pressure: 37 mbar Pressure Drop: 2.0 mbar Specific Gravity (Relative Density) of Gas: 1.52 | | | | | | | | | | | | | | | | | | | |
|----|-----|--|-------|-------|-------|-------|-------|-------|-------|-------|-------|-------|-------|-------|-------|-------|-------|-------|------|------|-------|
| | | Tubing Length (metres) | | | | | | | | | | | | | | | | | | | |
| DN | EHD | 3 | 6 | 9 | 12 | 15 | 20 | 25 | 30 | 40 | 50 | 60 | 70 | 80 | 90 | 100 | 110 | 120 | 130 | 140 | 150 |
| 12 | 15 | 1.02 | 0.74 | 0.61 | 0.53 | 0.48 | 0.42 | 0.38 | 0.35 | 0.30 | 0.25 | 0.23 | 0.22 | 0.21 | 0.20 | 0.19 | 0.18 | 0.18 | 0.17 | 0.16 | 0.18 |
| 15 | 19 | 2.24 | 1.60 | 1.31 | 1.14 | 1.03 | 0.89 | 0.80 | 0.73 | 0.64 | 0.53 | 0.49 | 0.46 | 0.43 | 0.41 | 0.39 | 0.38 | 0.36 | 0.35 | 0.34 | 0.38 |
| 22 | 25 | 5.55 | 3.96 | 3.25 | 2.83 | 2.53 | 2.20 | 1.98 | 1.81 | 1.57 | 1.29 | 1.20 | 1.12 | 1.06 | 1.01 | 0.96 | 0.92 | 0.89 | 0.85 | 0.83 | 0.92 |
| 28 | 31 | 9.50 | 6.76 | 5.54 | 4.81 | 4.32 | 3.75 | 3.36 | 3.07 | 2.67 | 2.19 | 2.03 | 1.90 | 1.79 | 1.70 | 1.62 | 1.56 | 1.50 | 1.44 | 1.40 | 1.56 |
| 32 | 37 | 17.87 | 12.72 | 10.42 | 9.05 | 8.11 | 7.04 | 6.31 | 5.77 | 5.01 | 4.10 | 3.81 | 3.56 | 3.36 | 3.19 | 3.05 | 2.92 | 2.81 | 2.71 | 2.62 | 2.92 |
| 40 | 46 | 28.76 | 20.26 | 16.51 | 14.27 | 12.75 | 11.03 | 9.85 | 8.98 | 7.77 | 6.33 | 5.86 | 5.47 | 5.16 | 4.89 | 4.66 | 4.46 | 4.28 | 4.13 | 3.98 | 4.46 |
| 50 | 62 | 66.64 | 47.21 | 38.59 | 33.45 | 29.93 | 25.94 | 23.22 | 21.21 | 18.38 | 15.02 | 13.91 | 13.02 | 12.28 | 11.65 | 11.11 | 10.64 | 10.23 | 9.86 | 9.52 | 10.64 |

Notes: 1) Flow rates based on Standard Conditions of 21C and 1 bar.
 2) Flow rates above include losses for four 90-degree bends and two end fittings. For tubing runs with additional bends or fittings, increase pipe length by the values given in Table F7.

TABLE F3 - Approximate discharge through TracPipe®/TracPipeCC® CSST in cubic metres per hour for BUTANE (relative density 2.07)

| | | Inlet Pressure: 28 mbar Pressure Drop: 2.0 mbar Specific Gravity (Relative Density) of Gas: 2.07 | | | | | | | | | | | | | | | | | | | |
|----|-----|--|-------|-------|-------|-------|-------|-------|-------|-------|-------|-------|-------|-------|------|------|------|------|------|------|------|
| | | Tubing Length (metres) | | | | | | | | | | | | | | | | | | | |
| DN | EHD | 3 | 6 | 9 | 12 | 15 | 20 | 25 | 30 | 40 | 50 | 60 | 70 | 80 | 90 | 100 | 110 | 120 | 130 | 140 | 150 |
| 12 | 15 | 0.87 | 0.63 | 0.52 | 0.46 | 0.41 | 0.36 | 0.33 | 0.30 | 0.26 | 0.22 | 0.20 | 0.19 | 0.18 | 0.17 | 0.16 | 0.16 | 0.15 | 0.15 | 0.14 | 0.16 |
| 15 | 19 | 1.92 | 1.37 | 1.13 | 0.98 | 0.88 | 0.77 | 0.69 | 0.63 | 0.55 | 0.45 | 0.42 | 0.39 | 0.37 | 0.35 | 0.34 | 0.32 | 0.31 | 0.30 | 0.29 | 0.32 |
| 22 | 25 | 4.76 | 3.39 | 2.79 | 2.42 | 2.17 | 1.89 | 1.69 | 1.55 | 1.35 | 1.11 | 1.03 | 0.96 | 0.91 | 0.86 | 0.82 | 0.79 | 0.76 | 0.73 | 0.71 | 0.79 |
| 28 | 31 | 8.14 | 5.79 | 4.75 | 4.13 | 3.70 | 3.21 | 2.88 | 2.63 | 2.29 | 1.87 | 1.74 | 1.63 | 1.54 | 1.46 | 1.39 | 1.33 | 1.28 | 1.24 | 1.20 | 1.33 |
| 32 | 37 | 15.31 | 10.90 | 8.93 | 7.75 | 6.95 | 6.03 | 5.41 | 4.94 | 4.29 | 3.52 | 3.26 | 3.05 | 2.88 | 2.74 | 2.61 | 2.50 | 2.41 | 2.32 | 2.24 | 2.50 |
| 40 | 46 | 24.64 | 17.36 | 14.15 | 12.23 | 10.93 | 9.45 | 8.44 | 7.70 | 6.66 | 5.42 | 5.02 | 4.69 | 4.42 | 4.19 | 3.99 | 3.82 | 3.67 | 3.54 | 3.41 | 3.82 |
| 50 | 62 | 57.11 | 40.46 | 33.07 | 28.66 | 25.65 | 22.23 | 19.90 | 18.17 | 15.75 | 12.87 | 11.92 | 11.16 | 10.52 | 9.98 | 9.52 | 9.12 | 8.76 | 8.45 | 8.16 | 9.12 |

Notes: 1) Flow rates based on Standard Conditions of 21C and 1 bar.
 2) Flow rates above include losses for four 90-degree bends and two end fittings. For tubing runs with additional bends or fittings, increase pipe length by the values given in Table F7.

TABLE F4 - Approximate pressure drop (mbar per metre) through TracPipe®/TracPipeCC® CSST at a given flow rate (cubic metres per hour), for NATURAL GAS (relative density 0.60)

| m ³ /hr | DN12 | DN15 | DN22 | DN28 | DN32 | DN40 | DN50 |
|--------------------|--------|--------|--------|--------|--------|--------|--------|
| 0.25 | 0.0121 | 0.0027 | 0.0004 | 0.0002 | - | - | - |
| 0.50 | 0.0534 | 0.0115 | 0.0018 | 0.0006 | 0.0002 | 0.0001 | - |
| 0.75 | 0.1272 | 0.0266 | 0.0042 | 0.0015 | 0.0004 | 0.0002 | - |
| 1.00 | 0.2357 | 0.0482 | 0.0076 | 0.0026 | 0.0007 | 0.0003 | 0.0001 |
| 1.25 | 0.3803 | 0.0765 | 0.0120 | 0.0041 | 0.0011 | 0.0005 | 0.0001 |
| 1.50 | 0.5621 | 0.1116 | 0.0175 | 0.0060 | 0.0017 | 0.0008 | 0.0001 |
| 1.75 | 0.7821 | 0.1535 | 0.0240 | 0.0082 | 0.0023 | 0.0010 | 0.0002 |
| 2.00 | 1.0413 | 0.2023 | 0.0315 | 0.0108 | 0.0030 | 0.0014 | 0.0002 |
| 2.25 | | 0.2581 | 0.0402 | 0.0137 | 0.0038 | 0.0017 | 0.0003 |
| 2.50 | | 0.3210 | 0.0499 | 0.0170 | 0.0047 | 0.0021 | 0.0004 |
| 2.75 | | 0.3910 | 0.0607 | 0.0206 | 0.0057 | 0.0026 | 0.0004 |
| 3.00 | | 0.4681 | 0.0725 | 0.0246 | 0.0068 | 0.0030 | 0.0005 |
| 3.25 | | 0.5523 | 0.0855 | 0.0290 | 0.0080 | 0.0035 | 0.0006 |
| 3.50 | | 0.6438 | 0.0996 | 0.0337 | 0.0094 | 0.0041 | 0.0007 |
| 3.75 | | 0.7426 | 0.1147 | 0.0388 | 0.0108 | 0.0047 | 0.0008 |
| 4.00 | | 0.8487 | 0.1310 | 0.0443 | 0.0123 | 0.0054 | 0.0009 |
| 4.25 | | 0.9621 | 0.1484 | 0.0501 | 0.0139 | 0.0060 | 0.0010 |
| 4.50 | | 1.0828 | 0.1669 | 0.0563 | 0.0156 | 0.0068 | 0.0012 |
| 4.75 | | | 0.1865 | 0.0628 | 0.0174 | 0.0075 | 0.0013 |
| 5.00 | | | 0.2072 | 0.0698 | 0.0193 | 0.0083 | 0.0014 |
| 5.25 | | | 0.2290 | 0.0771 | 0.0214 | 0.0092 | 0.0016 |
| 5.50 | | | 0.2520 | 0.0847 | 0.0235 | 0.0101 | 0.0017 |
| 5.75 | | | 0.2761 | 0.0928 | 0.0257 | 0.0110 | 0.0019 |
| 6.00 | | | 0.3013 | 0.1012 | 0.0280 | 0.0119 | 0.0021 |
| 6.25 | | | 0.3276 | 0.1100 | 0.0305 | 0.0130 | 0.0022 |
| 6.50 | | | 0.3551 | 0.1191 | 0.0330 | 0.0140 | 0.0024 |
| 6.75 | | | 0.3838 | 0.1287 | 0.0356 | 0.0151 | 0.0026 |
| 7.00 | | | 0.4135 | 0.1386 | 0.0384 | 0.0162 | 0.0028 |
| 7.25 | | | 0.4444 | 0.1489 | 0.0412 | 0.0174 | 0.0030 |
| 7.50 | | | 0.4765 | 0.1595 | 0.0442 | 0.0186 | 0.0032 |
| 7.75 | | | 0.5097 | 0.1706 | 0.0472 | 0.0198 | 0.0035 |
| 8.00 | | | 0.5440 | 0.1820 | 0.0504 | 0.0211 | 0.0037 |
| 8.25 | | | 0.5795 | 0.1938 | 0.0536 | 0.0224 | 0.0039 |
| 8.50 | | | 0.6162 | 0.2059 | 0.0570 | 0.0238 | 0.0042 |
| 8.75 | | | 0.6540 | 0.2185 | 0.0604 | 0.0252 | 0.0044 |
| 9.00 | | | 0.6929 | 0.2314 | 0.0640 | 0.0267 | 0.0047 |
| 9.25 | | | 0.7331 | 0.2447 | 0.0677 | 0.0281 | 0.0049 |
| 9.50 | | | 0.7743 | 0.2584 | 0.0715 | 0.0297 | 0.0052 |
| 9.75 | | | 0.8168 | 0.2724 | 0.0753 | 0.0312 | 0.0055 |
| 10.00 | | | 0.8604 | 0.2869 | 0.0793 | 0.0328 | 0.0058 |
| 12.00 | | | 1.2512 | 0.4161 | 0.1150 | 0.0471 | 0.0083 |
| 14.00 | | | | 0.5699 | 0.1574 | 0.0639 | 0.0114 |
| 16.00 | | | | 0.7483 | 0.2066 | 0.0833 | 0.0149 |
| 18.00 | | | | 0.9515 | 0.2626 | 0.1051 | 0.0188 |
| 20.00 | | | | 1.1796 | 0.3254 | 0.1295 | 0.0233 |
| 25.00 | | | | | 0.5125 | 0.2014 | 0.0365 |
| 30.00 | | | | | 0.7430 | 0.2889 | 0.0526 |
| 35.00 | | | | | 1.0170 | 0.3920 | 0.0717 |
| 40.00 | | | | | | 0.5106 | 0.0938 |
| 45.00 | | | | | | 0.6447 | 0.1189 |
| 50.00 | | | | | | 0.7942 | 0.1469 |
| 55.00 | | | | | | 0.9591 | 0.1780 |
| 60.00 | | | | | | 1.1393 | 0.2120 |
| 65.00 | | | | | | | 0.2490 |
| 70.00 | | | | | | | 0.2890 |
| 75.00 | | | | | | | 0.3320 |
| 80.00 | | | | | | | 0.3781 |
| 85.00 | | | | | | | 0.4271 |
| 90.00 | | | | | | | 0.4791 |
| 95.00 | | | | | | | 0.5341 |
| 100.00 | | | | | | | 0.5921 |

Notes: 1) Pressure drop information based on Standard Conditions of 21C and 1 bar.
 2) Flow rates / pressure drop information above include losses for four 90-degree bends and two end fittings. For tubing runs with additional bends or fittings, increase pipe length by the values given in Table F7.

TABLE F5 - Approximate pressure drop (mbar per metre) through TracPipe®/TracPipeCC® CSST at a given flow rate (cubic metres per hour), for PROPANE (relative density 1.52)

| m ³ /hr | DN12 | DN15 | DN22 | DN28 | DN32 | DN40 | DN50 |
|--------------------|--------|--------|--------|--------|--------|--------|--------|
| 0.25 | 0.0327 | 0.0072 | 0.0011 | 0.0004 | 0.0001 | 0.0001 | - |
| 0.50 | 0.1445 | 0.0301 | 0.0048 | 0.0016 | 0.0005 | 0.0002 | - |
| 0.75 | 0.3445 | 0.0696 | 0.0109 | 0.0038 | 0.0010 | 0.0005 | 0.0001 |
| 1.00 | 0.6382 | 0.1261 | 0.0197 | 0.0068 | 0.0019 | 0.0009 | 0.0001 |
| 1.25 | 1.0297 | 0.2001 | 0.0312 | 0.0106 | 0.0030 | 0.0013 | 0.0002 |
| 1.50 | 1.5219 | 0.2918 | 0.0454 | 0.0154 | 0.0043 | 0.0019 | 0.0003 |
| 1.75 | 2.1178 | 0.4014 | 0.0623 | 0.0212 | 0.0059 | 0.0026 | 0.0004 |
| 2.00 | 2.8195 | 0.5291 | 0.0819 | 0.0278 | 0.0077 | 0.0034 | 0.0006 |
| 2.25 | | 0.6751 | 0.1044 | 0.0353 | 0.0098 | 0.0043 | 0.0007 |
| 2.50 | | 0.8395 | 0.1296 | 0.0438 | 0.0121 | 0.0053 | 0.0009 |
| 2.75 | | 1.0225 | 0.1576 | 0.0532 | 0.0147 | 0.0064 | 0.0011 |
| 3.00 | | 1.2242 | 0.1885 | 0.0635 | 0.0176 | 0.0076 | 0.0013 |
| 3.25 | | 1.4446 | 0.2221 | 0.0748 | 0.0207 | 0.0089 | 0.0015 |
| 3.50 | | 1.6839 | 0.2587 | 0.0870 | 0.0241 | 0.0103 | 0.0018 |
| 3.75 | | 1.9423 | 0.2981 | 0.1001 | 0.0277 | 0.0118 | 0.0020 |
| 4.00 | | 2.2197 | 0.3403 | 0.1142 | 0.0316 | 0.0134 | 0.0023 |
| 4.25 | | 2.5162 | 0.3854 | 0.1292 | 0.0358 | 0.0151 | 0.0026 |
| 4.50 | | 2.8321 | 0.4335 | 0.1452 | 0.0402 | 0.0170 | 0.0030 |
| 4.75 | | | 0.4844 | 0.1622 | 0.0449 | 0.0189 | 0.0033 |
| 5.00 | | | 0.5382 | 0.1800 | 0.0498 | 0.0209 | 0.0036 |
| 5.25 | | | 0.5949 | 0.1989 | 0.0550 | 0.0230 | 0.0040 |
| 5.50 | | | 0.6546 | 0.2187 | 0.0605 | 0.0252 | 0.0044 |
| 5.75 | | | 0.7172 | 0.2394 | 0.0662 | 0.0276 | 0.0048 |
| 6.00 | | | 0.7827 | 0.2612 | 0.0722 | 0.0300 | 0.0053 |
| 6.25 | | | 0.8512 | 0.2838 | 0.0785 | 0.0325 | 0.0057 |
| 6.50 | | | 0.9226 | 0.3075 | 0.0850 | 0.0351 | 0.0062 |
| 6.75 | | | 0.9970 | 0.3321 | 0.0918 | 0.0378 | 0.0067 |
| 7.00 | | | 1.0743 | 0.3577 | 0.0989 | 0.0407 | 0.0072 |
| 7.25 | | | 1.1546 | 0.3842 | 0.1062 | 0.0436 | 0.0077 |
| 7.50 | | | 1.2378 | 0.4117 | 0.1138 | 0.0466 | 0.0082 |
| 7.75 | | | 1.3241 | 0.4402 | 0.1216 | 0.0498 | 0.0088 |
| 8.00 | | | 1.4133 | 0.4696 | 0.1297 | 0.0530 | 0.0094 |
| 8.25 | | | 1.5055 | 0.5000 | 0.1381 | 0.0563 | 0.0100 |
| 8.50 | | | 1.6008 | 0.5314 | 0.1468 | 0.0597 | 0.0106 |
| 8.75 | | | 1.6990 | 0.5638 | 0.1557 | 0.0633 | 0.0112 |
| 9.00 | | | 1.8002 | 0.5972 | 0.1649 | 0.0669 | 0.0119 |
| 9.25 | | | 1.9044 | 0.6315 | 0.1744 | 0.0706 | 0.0126 |
| 9.50 | | | 2.0116 | 0.6668 | 0.1841 | 0.0744 | 0.0133 |
| 9.75 | | | 2.1219 | 0.7031 | 0.1941 | 0.0784 | 0.0140 |
| 10.00 | | | 2.2352 | 0.7403 | 0.2044 | 0.0824 | 0.0147 |
| 12.00 | | | 3.2506 | 1.0738 | 0.2963 | 0.1182 | 0.0212 |
| 14.00 | | | | 1.4706 | 0.4055 | 0.1604 | 0.0289 |
| 16.00 | | | | 1.9311 | 0.5322 | 0.2089 | 0.0378 |
| 18.00 | | | | 2.4555 | 0.6765 | 0.2638 | 0.0480 |
| 20.00 | | | | 3.0442 | 0.8383 | 0.3249 | 0.0593 |
| 25.00 | | | | | 1.3206 | 0.5053 | 0.0928 |
| 30.00 | | | | | 1.9143 | 0.7250 | 0.1339 |
| 35.00 | | | | | 2.6202 | 0.9836 | 0.1826 |
| 40.00 | | | | | | 1.2812 | 0.2388 |
| 45.00 | | | | | | 1.6176 | 0.3027 |
| 50.00 | | | | | | 1.9927 | 0.3741 |
| 55.00 | | | | | | 2.4064 | 0.4531 |
| 60.00 | | | | | | 2.8587 | 0.5398 |
| 65.00 | | | | | | | 0.6340 |
| 70.00 | | | | | | | 0.7359 |
| 75.00 | | | | | | | 0.8454 |
| 80.00 | | | | | | | 0.9626 |
| 85.00 | | | | | | | 1.0873 |
| 90.00 | | | | | | | 1.2198 |
| 95.00 | | | | | | | 1.3599 |
| 100.00 | | | | | | | 1.5076 |

Notes:
 1) Pressure drop information based on Standard Conditions of 21C and 1 bar.
 2) Flow rates / pressure drop information above include losses for four 90-degree bends and two end fittings. For tubing runs with additional bends or fittings, increase pipe length by the values given in Table F7.

TABLE F6 - Approximate pressure drop (mbar per metre) through TracPipe®/TracPipeCC® CSST at a given flow rate (cubic metres per hour), for BUTANE (relative density 2.07)

| m ³ /hr | DN12 | DN15 | DN22 | DN28 | DN32 | DN40 | DN50 |
|--------------------|--------|--------|--------|--------|--------|--------|--------|
| 0.25 | 0.0455 | 0.0099 | 0.0016 | 0.0005 | 0.0002 | 0.0001 | 0.0000 |
| 0.50 | 0.2012 | 0.0414 | 0.0065 | 0.0023 | 0.0006 | 0.0003 | 0.0000 |
| 0.75 | 0.4797 | 0.0957 | 0.0150 | 0.0051 | 0.0014 | 0.0007 | 0.0001 |
| 1.00 | 0.8886 | 0.1736 | 0.0271 | 0.0093 | 0.0026 | 0.0012 | 0.0002 |
| 1.25 | 1.4336 | 0.2755 | 0.0429 | 0.0146 | 0.0041 | 0.0018 | 0.0003 |
| 1.50 | 2.1190 | 0.4017 | 0.0623 | 0.0212 | 0.0059 | 0.0026 | 0.0004 |
| 1.75 | 2.9486 | 0.5525 | 0.0855 | 0.0290 | 0.0080 | 0.0036 | 0.0006 |
| 2.00 | | 0.7283 | 0.1125 | 0.0381 | 0.0106 | 0.0046 | 0.0008 |
| 2.25 | | 0.9292 | 0.1433 | 0.0484 | 0.0134 | 0.0058 | 0.0010 |
| 2.50 | | 1.1555 | 0.1780 | 0.0600 | 0.0166 | 0.0072 | 0.0012 |
| 2.75 | | 1.4073 | 0.2165 | 0.0729 | 0.0202 | 0.0087 | 0.0015 |
| 3.00 | | 1.6849 | 0.2588 | 0.0870 | 0.0241 | 0.0103 | 0.0018 |
| 3.25 | | 1.9883 | 0.3051 | 0.1025 | 0.0284 | 0.0121 | 0.0021 |
| 3.50 | | 2.3177 | 0.3552 | 0.1192 | 0.0330 | 0.0140 | 0.0024 |
| 3.75 | | 2.6732 | 0.4093 | 0.1372 | 0.0380 | 0.0161 | 0.0028 |
| 4.00 | | | 0.4673 | 0.1565 | 0.0433 | 0.0182 | 0.0032 |
| 4.25 | | | 0.5293 | 0.1771 | 0.0490 | 0.0206 | 0.0036 |
| 4.50 | | | 0.5953 | 0.1990 | 0.0551 | 0.0230 | 0.0040 |
| 4.75 | | | 0.6652 | 0.2222 | 0.0615 | 0.0256 | 0.0045 |
| 5.00 | | | 0.7391 | 0.2467 | 0.0682 | 0.0284 | 0.0050 |
| 5.25 | | | 0.8170 | 0.2725 | 0.0754 | 0.0312 | 0.0055 |
| 5.50 | | | 0.8989 | 0.2997 | 0.0828 | 0.0343 | 0.0060 |
| 5.75 | | | 0.9849 | 0.3281 | 0.0907 | 0.0374 | 0.0066 |
| 6.00 | | | 1.0749 | 0.3578 | 0.0989 | 0.0407 | 0.0072 |
| 6.25 | | | 1.1689 | 0.3889 | 0.1075 | 0.0441 | 0.0078 |
| 6.50 | | | 1.2670 | 0.4213 | 0.1164 | 0.0477 | 0.0084 |
| 6.75 | | | 1.3691 | 0.4550 | 0.1257 | 0.0514 | 0.0091 |
| 7.00 | | | 1.4753 | 0.4901 | 0.1354 | 0.0552 | 0.0098 |
| 7.25 | | | 1.5856 | 0.5264 | 0.1454 | 0.0592 | 0.0105 |
| 7.50 | | | 1.6999 | 0.5641 | 0.1558 | 0.0633 | 0.0112 |
| 7.75 | | | 1.8183 | 0.6031 | 0.1666 | 0.0675 | 0.0120 |
| 8.00 | | | 1.9409 | 0.6435 | 0.1777 | 0.0719 | 0.0128 |
| 8.25 | | | 2.0675 | 0.6852 | 0.1892 | 0.0764 | 0.0136 |
| 8.50 | | | 2.1983 | 0.7282 | 0.2010 | 0.0811 | 0.0145 |
| 8.75 | | | 2.3331 | 0.7726 | 0.2133 | 0.0859 | 0.0153 |
| 9.00 | | | 2.4721 | 0.8183 | 0.2258 | 0.0908 | 0.0162 |
| 9.25 | | | 2.6153 | 0.8653 | 0.2388 | 0.0959 | 0.0171 |
| 9.50 | | | | 0.9137 | 0.2521 | 0.1011 | 0.0181 |
| 9.75 | | | | 0.9634 | 0.2658 | 0.1064 | 0.0191 |
| 10.00 | | | | 1.0144 | 0.2799 | 0.1119 | 0.0201 |
| 12.00 | | | | 1.4714 | 0.4057 | 0.1605 | 0.0289 |
| 14.00 | | | | 2.0151 | 0.5553 | 0.2177 | 0.0395 |
| 16.00 | | | | 2.6460 | 0.7289 | 0.2836 | 0.0516 |
| 18.00 | | | | | 0.9264 | 0.3580 | 0.0654 |
| 20.00 | | | | | 1.1481 | 0.4411 | 0.0808 |
| 25.00 | | | | | 1.8086 | 0.6860 | 0.1266 |
| 30.00 | | | | | 2.6217 | 0.9842 | 0.1827 |
| 35.00 | | | | | | 1.3353 | 0.2491 |
| 40.00 | | | | | | 1.7393 | 0.3258 |
| 45.00 | | | | | | 2.1959 | 0.4129 |
| 50.00 | | | | | | 2.7051 | 0.5103 |
| 55.00 | | | | | | | 0.6181 |
| 60.00 | | | | | | | 0.7363 |
| 65.00 | | | | | | | 0.8649 |
| 70.00 | | | | | | | 1.0038 |
| 75.00 | | | | | | | 1.1532 |
| 80.00 | | | | | | | 1.3130 |
| 85.00 | | | | | | | 1.4833 |
| 90.00 | | | | | | | 1.6639 |
| 95.00 | | | | | | | 1.8550 |
| 100.00 | | | | | | | 2.0566 |

Notes: 1) Pressure drop information based on Standard Conditions of 21C and 1 bar.
 2) Flow rates / pressure drop information above include losses for four 90-degree bends and two end fittings. For tubing runs with additional bends or fittings, increase pipe length by the values given in Table F7.

TABLE F7. Equivalent length of TracPipe®/TracPipeCC® (in metres) to be added to a pipe run for additional 90 degree bends and tees

| Size DN | 90 Degree Bend metres | Tee metres |
|--------------------|----------------------------------|-----------------------|
| 12 | 0.3 | 0.5 |
| 15 | 0.3 | 0.5 |
| 22 | 0.3 | 0.5 |
| 28 | 0.3 | 0.5 |
| 32 | 0.5 | 1.0 |
| 40 | 0.5 | 1.0 |
| 50 | 0.65 | 1.5 |