

Natural Gas Detection and Protection for Households

Protection for cookers, fires and other gas appliances



Natural Gas Risks

Natural gas is one of the safest forms of energy in use today. This is why it is used in households. However it is possible to cause problems through:

- mistakes such as forgetting to light a gas ring or
- natural causes like a pilot light blowing out

This becomes a bigger problem where there are confused, elderly or infirm people who may be less aware of what is going on around them.

In the worse case, leaking gas can build up to dangerous levels which can result in explosions.

The Amos 550 Natural Gas Detector (with optional valve) provides two key functions

- it detects leaks long before the gas reaches unsafe levels,
- it actively prevents danger by shutting off the gas supply to the appliance

Where can the detector be used?

The detector is specially designed for all household situations. In particular where appliances may be left unattended or there is a risk of gas flames blowing out or being forgotten to be lit. It is mainly used for gas cookers but also can be used to protect fires and other gas appliances.



Domestic & Commercial Gas Detection Systems

How it works

A simple gas detector (similar in size and operation to a smoke detector) is sited above the gas appliance. When gas leaks happen they are detected well before levels reach recommended safety limits.

When a leak is detected a red warning light comes on and an optional alarm sounds. Remote alarms can also be triggered.

An optional cut off valve can be connected into the gas supply feeding the appliance. With this valve, when a leak is detected, the gas supply to the appliance is automatically switched off, making the situation safe.

When the gas has dispersed the gas can be reconnected either automatically, when a button is pushed or only when a key is inserted. This last option allows only selected people to reconnect the gas.

Specification

Detector

Alarm trigger level:

Between 5% and 20% of Lower Explosive Limit (LEL)

Alarm: Red warning light.

Audible sounder, 85 dB at 3 m (can be disabled)

Outputs: 2 relays

240v powered out (for valve control) or Volt free (for remote signalling)

Reset operation:

Only permitted when gas has cleared.

Alarm reset:

Automatic or push button or key switch

Size: 110 * 110 * 57 mm (4.3 * 4.3 * 2.2 inch)

Weight: 420 g (15 oz)

Power: 240v ac or 12 dc or 24 dc

Life 5 years

Model number: 550

Installation: 1 gang pattress box

Shut off valve (option)

Installation: in line.

Requires CORGI registered fitter

Using the detector and valve ensures that dangerous build ups of gas cannot occur.

Installation

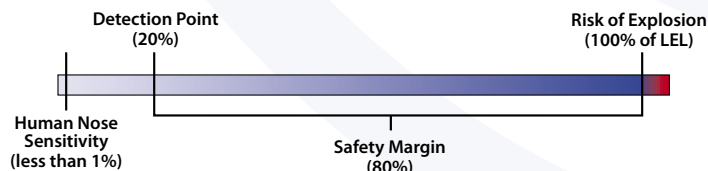
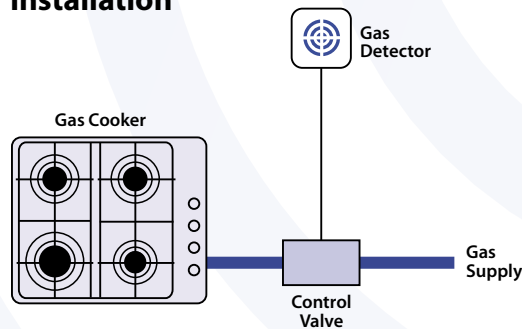

Amos gas detectors have been used for many years in a wide range of applications where gas presents a risk to life or property. Our extensive experience in detector design and manufacture has made us the detector of choice for many councils, companies and housing associations.

Living Safely with Gas



AMOS Detection Limited

Unit 6, Sovereign Park
Laporte Way, Luton
Beds LU4 8EL

Telephone: 01582 506130

Fax: 01582 506124

email: enquiries@amos.uk.com

www.amos.uk.com

Manufactured by Ruston Electronics Ltd an ISO 9001:2000 Approved Company.

The content of this document is subject to change and may not be used as part of a contract.