



**MODEL 550**  
**NATURAL GAS DETECTOR**  
12V dc



**INSTRUCTION MANUAL**

Read these instructions carefully before installation

## **CAUTION**

**Detectors Must Be Installed By Competent Persons. Isolate Electrical Power Before Starting Installation.**

**Electrical Wiring Must Be Carried Out Properly In Accordance With Current Electrical Regulations.**

### **1.0 Introduction**

- 1.1 The Model 550 detector is designed to provide, within the scale of 5% to 20% of the Lower Explosion Limit ( LEL ) a visual and audible alarm when Natural gas is present.

### **2.0 Description Of Gas Alarm**

- 2.1 Natural gas is detected by a highly sensitive semi – conductor device which is operated and monitored by the electrical circuit.
- 2.3 Visual and audible indicators show the system status.

### **3.0 Detector and Sensor Placement**

- 3.1 Sensor: Natural gas is lighter than air, therefore the sensor should be located either side of the potential leak source and not more than 5 metres in the horizontal plane, and not more than 30cm from the ceiling.
- 3.2 Detector: Site in the optimum detection position and where it can be seen and heard.
- 3.2a The system is designed to operate within a building in a location with free access to air in the room. It is not designed or certified for use in defined areas of hazard.

### **4.0 Where not to site detectors and sensors**

- Outside the building.
- In a cupboard or confined space.
- Next to a door or window.
- Next to an extractor fan.
- In areas where the temperatures are likely to drop below - 10° C or rise above + 40° C.
- Damp or humid areas ( steam from kettles or domestic cookers )
- Protect the sensors from dusty or dirty site conditions.

## 5.0 Installation

- 5.1 The detector is supplied complete with a surface mount electrical box to house the connector block and fitted with a bracket to secure the detector.  
Please refer to the connection drawing.
- 5.2 Low voltage operated detector power supplies (12V dc) should be connected to the terminal blocks as follows: red lead to + L to No 1 terminal and black lead to – N to No 2 terminal.
- 5.3 The detector is fitted onto the mounting box by placing the lugs on the bracket into the holes in the back of the case and sliding downwards to locate. Take care to ensure the cables are placed within the mounting box.
- 5.4 Remote sensor is soldered to the printed circuit board with a terminal block and fitted onto the inner surface of the cover plate secured by two fixing screws. The sensor box must be fitted in a vertical position. Connect detector cable to sensor terminals and secure lid with the screws provided.
- 5.5 The distance between the detector and the sensor should not exceed 5 metres.

**Note :** Cable core sizes from the detector to sensor should be not less than 1.0 (mm ). It is of importance to ensure the colour codes at the detector correspond to the number on the sensor Terminal block ie. Match Red to 1, Black to 2 and Blue to 3. The detector will not operate with the incorrect wiring.

## 6.0 Remote Sensor ( If applicable )

- 6.1 Remote sensor is provided with a patresse mounting box. Choose the optimum location for the sensor, fix the box to the wall, connect the wiring cable to the terminals as shown on the wiring connection drawing.
- 6.2 The maximum cable run from the sensor to the detector should not exceed 5 metres using 1.0 mm sq three core cable. Ensure the colour codes at the detector terminal block sensor match. ( Refer above ) Failure to comply with these instructions will cause the sensor to be inoperative.

## 7.0 Relay Outputs: Detector in quiescent mode.

Relay RL / 1 ( Yellow Cables ) these contacts are volt free , **will close** in alarm conditions.

Relay RL / 2 ( Violet Cables ) these contacts are volt free , **will open** in alarm conditions.

## The Detector In Operation

- 8.1 **Quiescent State:** When the electrical supply to the detector is connected the green indicator will remain illuminated as long as power is applied. **The First three minutes after power is applied**, the audible alarm and relays will not operate. This allows the sensor to stabilize.  
Note: Red LED may flash for a few seconds.
- 8.2 **ALARM:** The red indicator will light, an audible signal will sound and the alarm relays will change state thus causing the gas cut off valve to close (if fitted) and second relay closes (RL2).
- RESET:** The detector will stay in an alarm condition until the reset button on the base of the unit is pushed.

### 8.0 Technical Specification – Model 550

Gases Detected:	Natural Gas (Methane)
Alarm Level:	Within the scale 5% to 20% LEL
Alarm Sound Level:	85 Decibels (d B) at 3m
Sensor responses time:	Inhibited initially < 3/4 minutes, then 10 seconds.
Indicators:	Power on: Green LED Alarm: Red LED
Relay Contacts:	Rated @ 10 amp. NI
Input Supply Voltage:	12V dc
Fuse Rating:	3A un-switched outlet
Power Consumption:	< 0.75 ma
Temperature Range:	- 10° C to + 40° C
Dimensions (mm):	110 x 110 x 57(mm)
Weight:	Approx. 420g

## AMOS SERIES CONNECTOR BLOCK

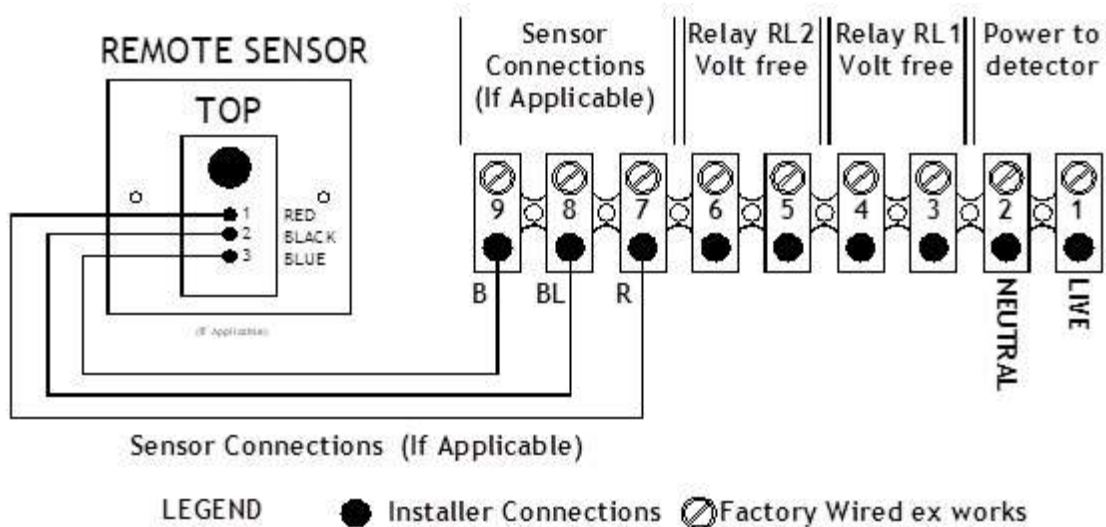

## INSTALLER TERMINAL CONNECTIONS

**RELAY RL2 CONTACTS ARE NORMALLY CLOSED – DETECTOR IN QUIESENT STATE.**

IF A POWERED OUTPUT IS REQUIRED. (say to power solenoid cut off valve)

1. DISCONNECT VIOLET ON TERMINAL 5 AND CONNECT TO TERMINAL 1
2. FIT LINK TO CONNECT TERMINAL 5 TO TERMINAL 2

**RELAY RL1 CONTACTS ARE NORMALLY OPEN – DETECTOR IN QUIESENT STATE.**

IF POWERED OUTPUT IS REQUIRED. (Say to power beacon or audible device)

3. DISCONNECT YELLOW WIRE ON TERMINAL 3 AND CONNECT TO TERMINAL 1
4. FIT LINK TO CONNECT TERMINAL 3 TO TERMINAL 2

### Detector cable tails. Colour code and terminals:

SENSOR If applicable	RELAY RL2	RELAY RL1	AC MAINS
RED (7)	Violet Stripe (5)	Yellow (3)	Red - Live (1)
BLACK (8)	Violet (6)	Yellow / Stripe (4)	Black - Neutral (2)
BLUE (9)			

## GUARANTEE

We guarantee your new gas detector for one year from the date of purchase by the purchaser, to be free from defects in materials and workmanship under normal use and service. We will, at our discretion, repair, replace or refund the price of any part of the detector which is found to be defective in either materials or workmanship under normal use and service during the guarantee period. We shall be under no obligation to repair, replace or refund the price of the units which are found to be defective in anyway due to damage, neglect, unreasonable use or have been dismantled. Defective units should be returned to Amos Detection, , Unit 15, Wedgwood Gate, Wedgwood Way, Stevenage, Hertfordshire, SG1 4SU

### MANUFACTURERS CALIBRATION CERTIFICATE

Model 500 Serial No: ..... Pt. No:..... Voltage: 12V dc

This unit has been calibrated in Natural Gas to alarm within the scale 5% to 20% LEL

Signed for Amos Detection:

Date: