

Natural Gas Detection and Protection for Households, Caravans & Boats

Protection for cookers, fires and other gas appliances



Flammable Gas Risks

Natural gas and Liquid Petroleum Gas (LPG) are some of the safest forms of energy in use today. This is why it is used in households. However it is possible to cause problems through:

- mistakes such as forgetting to light a gas ring or
- natural causes like a pilot light blowing out.

This becomes a bigger problem where there are confused, elderly, or infirm people who may be less aware of what is going on around them.

In the worse cases, leaking gas can build up to dangerous levels which can result in explosions.

The Amos range of flammable gas detectors (with optional valve) provide two key functions

- they detect leaks long before the gas reaches unsafe levels
- they actively prevent danger by shutting off the gas supply to the appliance.

Where can the detector be used?

The detector is specially designed for all household situations. In particular where appliances may be left unattended or there is a risk of gas flames blowing out or being forgotten to be lit. It is mainly used for gas cookers but also can be used to protect fires and other gas appliances.



Domestic & Commercial Gas Detection Systems

How it works

A simple gas detector (similar in size and operation to a smoke detector) is sited above the gas appliance. When gas leaks happen they are detected well before levels reach recommended safety limits.

When gas is detected a red warning light comes on and an optional alarm sounds. Remote alarms can also be triggered.

An optional cut off valve can be connected into the gas supply feeding the appliance. With this valve, when a leak is detected, the gas supply to the appliance is automatically switched off, making the situation safe.

When the gas has dispersed the gas can be reconnected either automatically, when a button is pushed or only when a key is inserted. This last option allows only selected people to reconnect the gas.

Using the detector and valve ensures that dangerous build ups of gas cannot occur.

Specification

Detector

Alarm trigger level:

Between 5% and 20% of Lower Explosive Limit (LEL)

Alarm: Red warning light.

Audible sounder, 85 dB at 3 m (can be disabled)

Outputs: 2 relays,

240v powered out (for valve control) or

Volt free (for remote signalling)

Reset Operation:

Only permitted when gas has cleared.

Alarm reset: Automatic or push button

Size: 110* 110* 57mm (4.3* 4.3* 2.2 inch)

Weight: 420g (15oz)

Power: 240v ac or 12 dc or 24dc

Expected serviceable life: 5 years

Models: Natural gas 550, LPG 650

Installation: 1 gang pattress box

Shut off valve (option)

Installation: in line

Requires Gas Safe Engineer

Installation

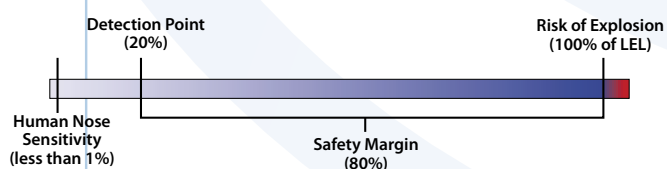
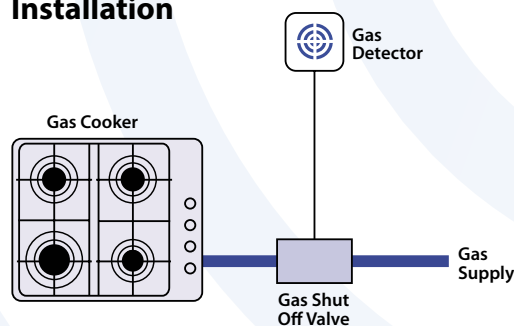

Amos gas detectors have been used for many years in a wide range of applications where gas presents a risk to life or property. Our extensive experience in detector design and manufacture has made us the detector of choice for many councils, companies and housing associations.

*Manufactured by Arkle Electronic Systems Ltd an ISO 9001:2001 company
The content of this document is subject to change and may not be used as part of a contract*

Living Safely with Gas



AMOS Detection is a trading name of Arkle Electronic Systems Ltd

Unit 15 Wedgwood Gate
Wedgwood Way
Stevenage
Herts SG1 4SU

Tel: 01438 721710
Fax: 01438 726565
email: info@amos.uk.com
www.amos.uk.com